

MUS3 Bolt Tension Secondary Cleaner Installation, Operation and Maintenance Manual

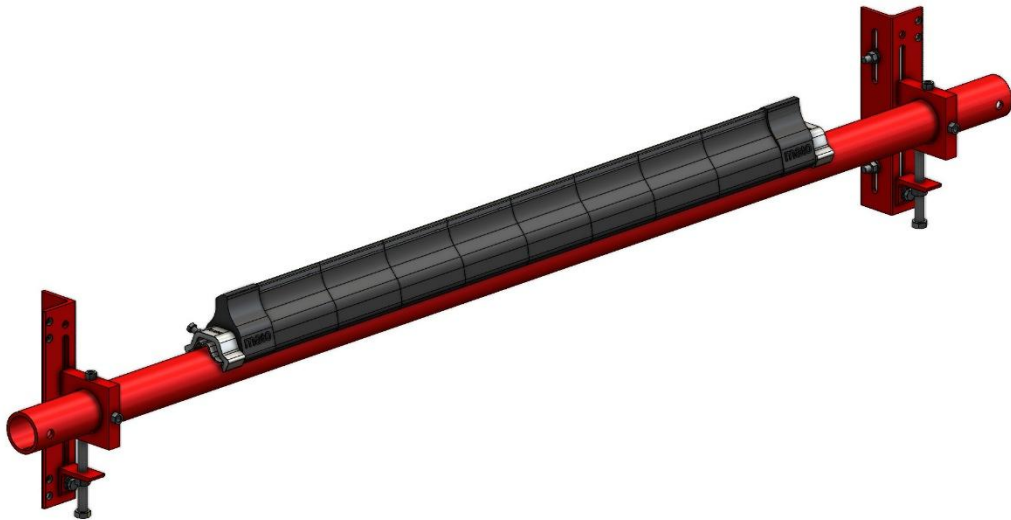

Purchase Date: _____

Purchased From: _____

Installation Date: _____

This information will be helpful for any future inquiries or questions about belt cleaner replacement parts, specifications or troubleshooting.

Contents

- Section 1 – Important Information..... 4**
 - 1.1 General Introduction..... 4
 - 1.2 User Benefits 5
 - 1.3 Service Option 5
- Section 2 – Safety Considerations and Precautions..... 5**
 - 2.1 Stationary Conveyors..... 5
 - 2.2 Operating Conveyors..... 7
- Section 3 – Pre-installation Checks and Verifications..... 8**
 - 3.1 Checklist 8
- Section 4 – Installation Instructions 9**
 - 4.1 MUS3-BT Cleaner – Mounting..... 10
- Section 5 - Trouble shooting..... 14**
- Section 6 -Maintenance 15**
 - 6.1 New Installation Inspection 15
 - 6.2 Visually inspect belt cleaner on a regular basis 15
 - 6.3 Routine Physical Inspection/adjustments..... 16
 - 6.4 Spare Parts and Specifications 16
- Section 7 - Specifications: 16**

Section 1 – Important Information

1.1 General Introduction

This manual is intended to help you understand how this product operates and to assist you in achieving maximum efficiency throughout its service life. For the product to function safely and effectively, it is important that the information and guidelines provided are fully understood and followed. Within this manual you will find safety precautions, installation instructions, maintenance procedures, and troubleshooting guidance. If you encounter questions or issues not addressed here, please visit our website or contact our Customer Service Department.

Please review this manual carefully and ensure it is provided to anyone who will be directly involved in the installation, operation, or maintenance of this cleaner. Although the installation and servicing procedures have been designed to be as straightforward as possible, proper installation along with routine inspections and maintenance are still necessary to keep the cleaner operating at peak performance.

Customer Service:

Australia/South-East Asia

MATO Australia Pty Ltd.
Tel: +61 1300 850 795
maus@mato.com.au

United Kingdom

MATO Industries Ltd
Tel: +44 (0) 1254 3876 38
info@mato.co.uk

South Africa

MATO Products Pty Ltd.
Tel: +27 (0) 1192 3602 4
matosales@multotec.co.za

China

MATO Industrial Technology
Tel: +86 5374 5337 99
info@mato.com.cn

North America

MATO Corp
Tel: +1(1) 3042 551280
info@mato-usa.com

South America

MATO LATAM
Tel: +57 3173 6207 51
csouto@mato.latam.com

Germany - Europe

MATO GmbH & Co Kg
Tel: +49 (0) 6108 906 0
beltlacing@mato.de

Visit www.mato.com.au for other MATO locations and products.

1.2 User Benefits

Proper installation along with consistent maintenance can deliver the following advantages for your operation:

- Decreased conveyor downtime
- Reduced labour hours
- Lower overall maintenance budget requirements
- Extended service life for the belt cleaner and other conveyor components

1.3 Service Option

The MUS3 secondary cleaner is engineered for straightforward installation and servicing by your onsite personnel. If you would rather have full turn-key factory service, please reach out to your local MATO Field Representative.

Section 2 – Safety Considerations and Precautions

Before installing or operating the MUS3 secondary cleaner, it is essential to review and understand the safety information provided. Various set-ups, maintenance, operational tasks involve contact with stationary and operating conveyors. Each situation requires adherence to its specific safety protocol.

2.1 Stationary Conveyors

The following tasks are carried out when the conveyor is stationary and isolated:

- Installation
- Blade replacement
- Repairs
- Tension adjustments
- Cleaning

DANGER

It is essential that all Lockout/Tagout regulations are followed before performing any of the above activities. Not applying Lockout/Tagout procedures exposes personnel to unexpected movement of the conveyor belt, which can cause uncontrolled action of the belt cleaner. Serious injury or fatal consequences may result.

Before working:

- Lockout/Tagout the conveyor power source
- Follow site regulations/instructions for belt maintenance
- ensure work site is safe to carry out work

WARNING

Use Personal Protective Equipment (PPE):

(as per site requirements)

- Safety eyewear
- Hardhats
- Safety footwear
- Safety gloves

Close quarters, springs and heavy components create a worksite that compromises a worker's eyes, feet and skull. PPE must be worn to control the foreseeable hazards associated with conveyor belt cleaners. Serious injuries can be avoided.

2.2 Operating Conveyors

There are two routine tasks that must be performed while the conveyor is running:

- Inspection of the cleaning performance
- Dynamic troubleshooting

DANGER

Every belt cleaner presents an in-running nip hazard. Never touch or interfere with a cleaner while it is in operation. Hazards associated with an operating cleaner can result in immediate amputation or entrapment. Do not attempt to make any adjustments while the cleaner is running.

WARNING

Unexpected belt tears or projections may catch on the cleaner, causing sudden and forceful movement of the cleaner assembly. Loose or flailing components can lead to severe injury or death.

WARNING

Belt cleaners can also become projectile hazards. Maintain as much distance from the cleaner as reasonably possible and always wear appropriate PPE. Flying debris can cause serious harm.

Section 3 – Pre-installation Checks and Verifications

3.1 Checklist

- Verify that the cleaner size matches the belt width
- Review the “Tools Needed” list at the top of the installation instructions (page 9)
- Inspect the conveyor site:
 - Ensure the conveyor being serviced, along with any upstream/downstream conveyors, is fully isolated in accordance with regulatory and site procedures
 - Determine whether the cleaner will be installed on a chute
 - Identify if the installation is on an open head pulley that will require mounting structure
 - Check for any obstructions that may necessitate adjustments to the cleaner’s location
 - Carry out a complete risk assessment and safe method statement as required by site standards for the work area, and prepare a job plan based on the instructions provided here

Note:

That the installation instructions provided should be regarded as typical guidelines and recommendations. These installation instructions may not fully reflect site conditions and/or safety requirements.

Section 4 – Installation Instructions

MUS3-BT Secondary Cleaner

MUS3-BT - MOUNTING

Tools required:

- Rule
- Tape measure
- Marking pen
- Level
- 11/16" (17mm) spanner
- 3/4" (19mm) spanner
- 15/16" 24mm spanner
- Pinch bar

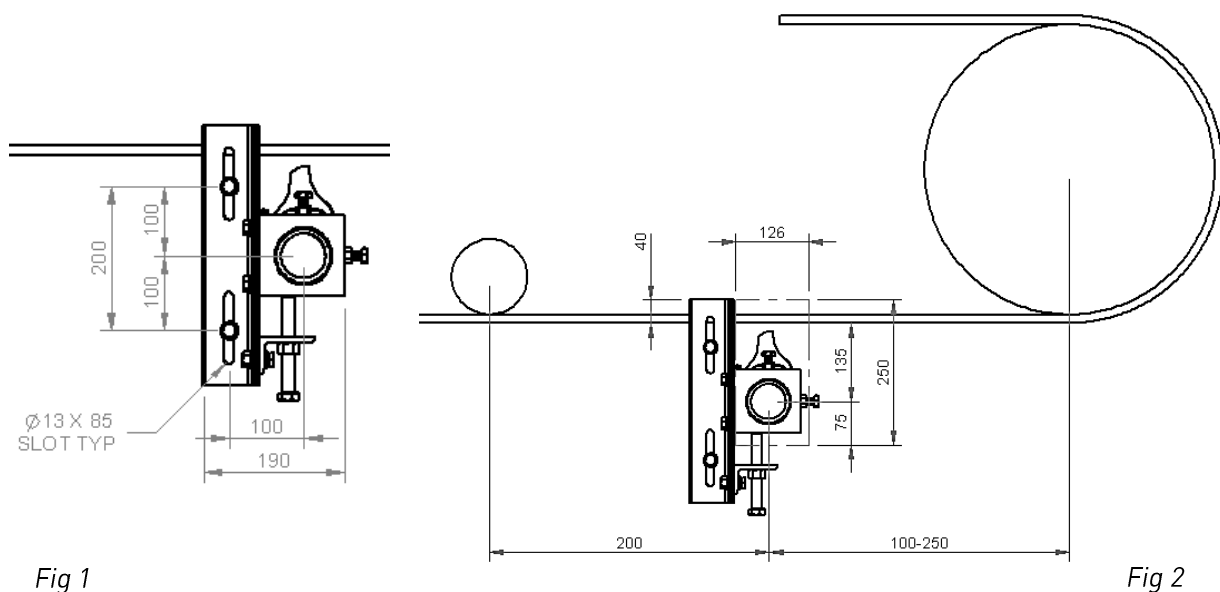

**Mounting Bracket
Detail**

**Secondary Cleaner
Location Position**

*Physically lock out and tag the conveyor at the power source
before you begin cleaner installation.*

4.1 MUS3-BT Cleaner – Mounting

- 1- The ideal position for the MUS3 Secondary Cleaner is 100mm to 250mm behind the tangent point where the conveyor belt leaves the pulley (the tangent point) refer to fig 2.

(The use of a pressure roller is advised to provide positive pressure of the belt surface to the cleaner blade. If more than one secondary cleaner is to be installed, the distance between the cleaner shafts should be no less than 250mm.)

- 2- The mounting bracket top face is to be 40mm above the bottom face of the belt (bracket to be perpendicular with belt). Using the angle bracket as a template mark out the mounting holes with the fasteners to be centered in mounting slots to allow for optimal adjusting if required (fig 3)
- 3- Using the mounting bracket as marking out template. Mark out mounting chute cut-out for shaft installation. Cut-out is to be flush with the face of the angle bracket perpendicular to the chute and flush with top face of bracket (flush with bottom face of belt) (fig 3)

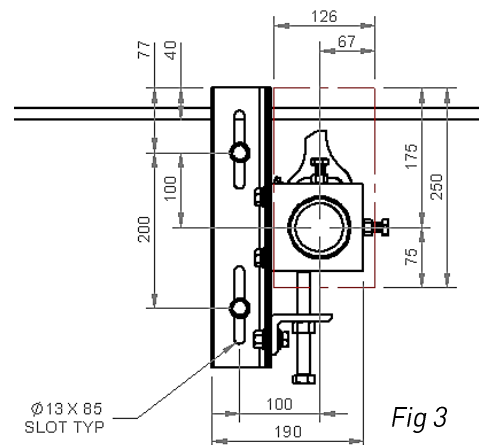

- 4- secure the mounting bracket to structure with supplied fasteners. (fig 4)

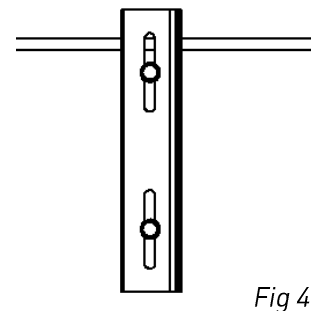

- 5- Mount adjusting tensioner brackets.
(fig 5)

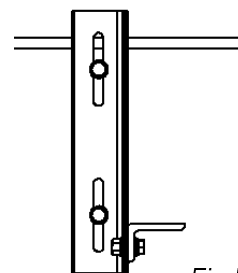

Fig 5

- 6- Mount far side shaft clamp block.
Clamp block to rest on tensioner adjusting bolt.
(fig 6)

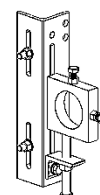

Fig 6

- 7- Insert shaft to far side clamp block
Slide shaft across as far as possible.
(fig 7)

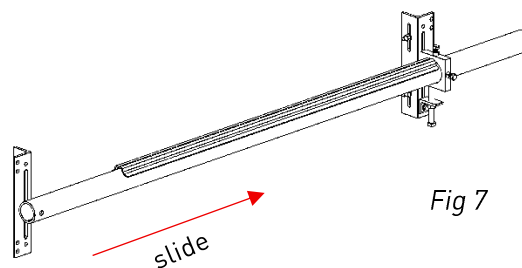

Fig 7

- 8- mount near side clamp block.
Slide shaft to near side clamp block,
Shaft to be centered to belt width.
Shaft end clamp block fasteners to be tensioned
(fig 8, 9)

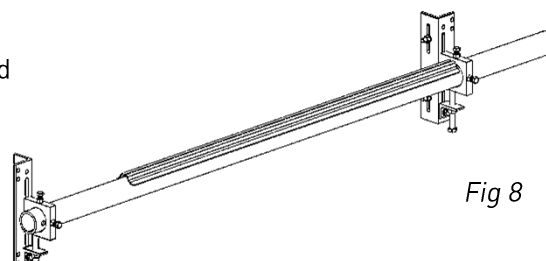

Fig 8

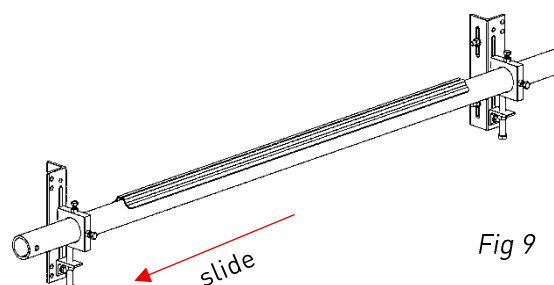

Fig 9

- 9- Fit end stop, end blade and blade to far side.
Slide on end blade and blades then for near side end blade
And end stop.
(fig 10, 11)

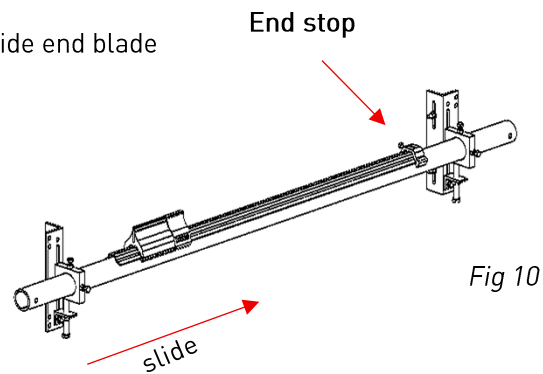

Fig 10

- 10- Fit tension bolts M16 x 130 to both adjusting
tensioner brackets, wound bolts up until blades
make contact to belt.
(fig 12, 13)

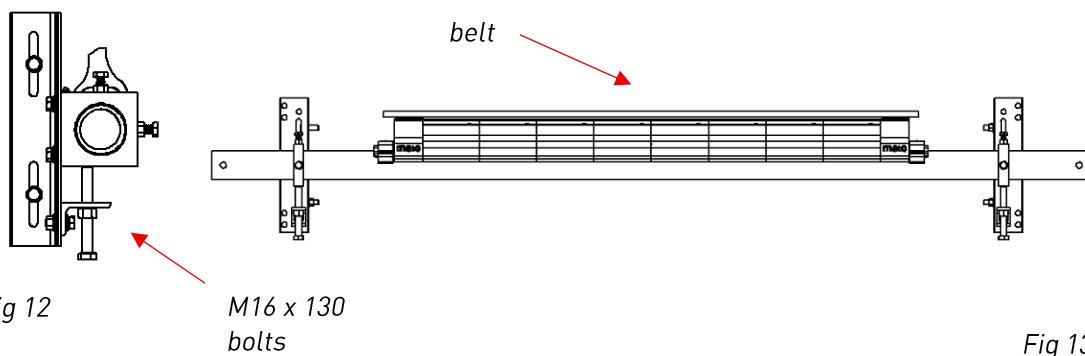

Fig 12

M16 x 130
bolts

Fig 13

- 11- Using the supplied cushion angle gauge,
Confirm that cushion angle to belt is correct.
Adjust if necessary
(fig 14)

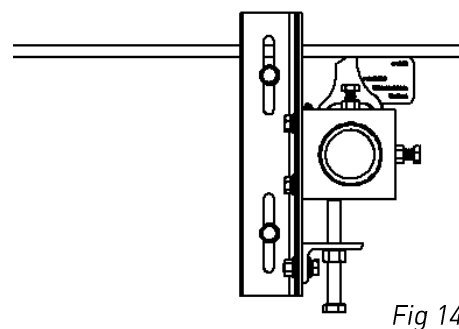

Fig 14

- 12- Once blade makes contact to belt, increase dimensions 'B' refer to fig 15 by 4 – 6mm to set blade tension. Tighten all locking nuts, refer to fig (fig 15)

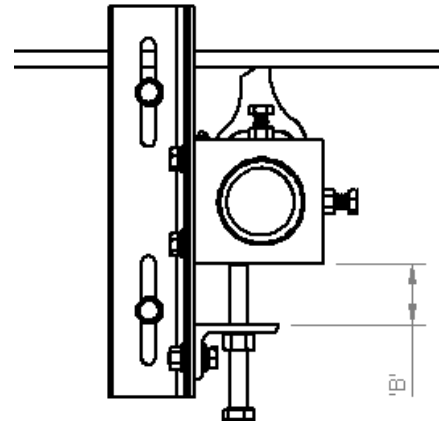

Fig 15

- 13- Test run conveyor and inspect cleaner performance.
Run conveyor for 15minutes to determine if there is excess vibration and efficiency of cleaner.

Section 5 - Trouble shooting

PROBLEM	POSSIBLE CAUSE	POSSIBLE SOLUTION
Vibration or noise	Cleaner locking bolts not secure	Check and tighten all bolts and nuts
	Cleaner not set correctly	Ensure cleaner set up properly (check tip angle before tension is applied to belt)
	Belt flap	Install pressure or stabilising rollers
	Shaft flex	Reinforced shaft may be required
	Cleaner over/under tensioned	Ensure cleaner is correctly tensioned
Cleaner being pushed away from belt	Cleaner not set correctly	Ensure cleaner set up properly (check tip angle before tension is applied to belt)
	Material build up in chute	Ensure cleaner is not located too close to back of chute, allowing build up
	Cleaner under tensioned	Ensure cleaner is correctly tensioned
	Excessive sticky material	Install spray bar Increase tension
Damaged belt cover	Cleaner over tensioned	Ensure cleaner is correctly tensioned
	Cleaner tip damaged	Check tips for wear, damage and chips. replace if necessary
	Attack angle is not correct	Ensure cleaner set up properly (check tip angle before tension is applied to belt)
	Material build up in chute	Ensure cleaner is not located too close to back of chute, allowing build up
Unusual wear or damage to blade	Cleaner not set correctly	Ensure cleaner set up properly (check tip angle before tension is applied to belt)
	Wear profile in belt cover	Adjust/install pressure roller to flatten belt
	Belt flap	Ensure cleaner set up properly
	Mechanical splice damaging cleaner	Repair, skive or replace splice
Material passing cleaner	Cleaner not set up correctly	Ensure cleaner set up properly
	Cleaner tension too low	Ensure cleaner is correctly tensioned
	Cleaner tips worn or damaged	Check tips for wear, damage and chips. replace if necessary
	Cleaner being overburdened	Install additional secondary cleaner
	Cleaner cannot conform	Install pressure roller behind secondary cleaner
Missing material in belt center only	Wear profile in belt cover	Adjust/install pressure roller to flatten belt
	Cleaner tips worn/damaged	Check tips for wear, damage and chips. replace if necessary
Missing material on outer edges only	Wear profile in belt cover	Adjust/install pressure roller to flatten belt
	Cleaner tips worn/damaged	Check tips for wear, damage and chips. replace if necessary

Section 6 -Maintenance

MATO belt cleaners are built to function with minimal attention; some servicing is still necessary to keep performance at a high level. Once the cleaner has been installed, a routine maintenance schedule should be established. Following such a schedule helps ensure the cleaner continues to run at peak efficiency and allows potential issues to be detected and resolved before the cleaner fails.

All safety requirements for inspecting the equipment—whether stationary or in operation—must be followed. The MUS3 Secondary cleaner operates directly behind the pulley where the conveyor belt leaves the head pulley. While the belt is in motion, only visual checks are permitted. Any service activities must be carried out only when the conveyor is shut down, and proper lockout/tagout procedures must be strictly observed.

6.1 New Installation Inspection

After the cleaner has been operating for several days, carry out a visual review to confirm that it is functioning correctly. Make any required adjustments at this time.

6.2 Visually inspect belt cleaner on a regular basis

A periodic visual check of both the cleaner and the belt can indicate:

- Whether the spring(tension) length matches the specification needed for proper tensioning
- Whether the belt surface appears clean or shows sections with material build up
- Whether the blade shows excessive wear and should be replaced
- Whether the blade or any other cleaner components show signs of damage
- Whether fugitive material has accumulated on the cleaner or within the transfer area
- Whether there is any belt cover damage
- Whether the cleaner is vibrating or bouncing on the belt
- If a snub pulley is installed, whether there is material build up on the pulley

If any of these conditions are present, decide when the conveyor can be safely shut down to perform cleaner maintenance.

6.3 Routine Physical Inspection/adjustments

With the conveyor fully stopped and properly locked and tagged out, conduct a hands-on inspection of the cleaner, including the following tasks:

- Remove any material build up from the cleaner blade and shaft
- Examine the blade closely for wear or damage and replace it if necessary
- Inspect blade end stops to confirm correct installation and condition. replace if required
- Verify that the blade maintains full contact with the belt
- Check the cleaner shaft for any signs of damage
- Inspect all fasteners for tightness and wear; tighten or replace where needed
- Replace any cleaner components that are worn or damaged
- Check the blade-to-belt tension and adjust it if needed referring to step 11 on Page 12
- After all maintenance steps are completed, run the conveyor to confirm the cleaner is functioning as expected

6.4 Spare Parts and Specifications

The MUS3 secondary cleaner is unique within itself to have a parallelogram designed into the cushion allowing constant blade angle attacking to the material flow, this allows for automatic adjustability within the cleaner for when the belt thickness can vary. The MUS3 is well suited for conveyor belts with mechanical fasteners when the tungsten impact blade is applied

Section 7 - Specifications:

- Blade widths available from 450mm – 2000mm
- Blade material tungsten carbide (TI) = tungsten impact for mechanical fasteners
- MUS3 secondary cleaners are supplied with a dual tensioned end assembly
- Belt speeds up to 5.0m/s
- Blade material tungsten carbide
- Temperature rated -35°C – 85°C
- Suitable for conveyors fitted with mechanical fasteners
- suited for reversing belts

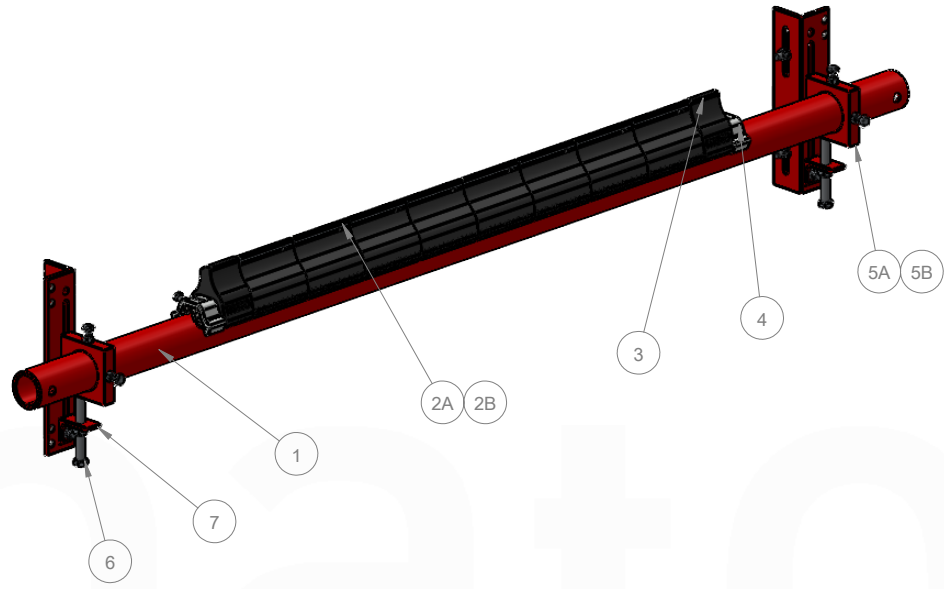

BELT WIDTH	BLADE QTY.	CLEANED WIDTH
450	2	450
600	3	600
750	4	750
900	5	900
1050	6	1050
1200	7	1200
1400	8	1350
1500	9	1500
1600	9	1500
1800	12	1800
2000	13	1950

ITEM NO.	DESCRIPTION	QTY.	PART No.
1	MUS3 SHAFT SUITS 450mm	1	81 200 21 01
	MUS3 SHAFT SUITS 600mm		81 200 21 02
	MUS3 SHAFT SUITS 750mm		81 200 21 03
	MUS3 SHAFT SUITS 900mm		81 200 21 04
	MUS3 SHAFT SUITS 1050mm		81 200 21 05
	MUS3 SHAFT SUITS 1200mm		81 200 21 06
	MUS3 SHAFT SUITS 1400mm		81 200 21 07
	MUS3 SHAFT SUITS 1500mm		81 200 21 08
	MUS3 SHAFT SUITS 1600mm		81 200 21 09
	MUS3 SHAFT SUITS 1800mm		81 200 21 10
	MUS3 SHAFT SUITS 2000mm		81 200 21 11

ITEM NO.	DESCRIPTION	QTY.	PART No.
2A	MUS3 TI BLADE CUSHION 45 DURO	SEE CHART	82 240 00 02
2B	MUS3 TI BLADE CUSHION 65 DURO		82 240 00 03
2C	MUS3 POLYURETHANE BLADE 150mm		81 250 00 02
3	MUS3 POLY END BLADE 75MM 85 SHORE	2	81 240 00 06
4	MUS2,3 & 4 END STOP	2	81 240 00 07
5A	SHAFT MOUNTING BLOCK 60.3	2	82 232 14
5B	SHAFT MOUNTING CLAMP 76.1		81 274 12
6	M16 X 130 STAINLESS STEEL ADJUSTING BOLT	2	81 231 16
7	ADJUSTING ANGLE BRACKET	2	81 312 21

REVISIONS				MACHINING AND FABRICATION TOLERANCES UNLESS OTHERWISE SPECIFIED: (ALL DIMENSIONS IN mm) DIMENSIONAL TOLERANCE: PIPE STRAIGHTNESS X.X: ±1.0 X.XX: ±0.5 X.XXX: ±0.1 X.XXX: ±0.01 ANGLE: ±1.0° X.X: ±0.5° X.XX: ±0.5° THERMAL CUTTING: ±1.0 WELDING: ±2.0 DIMENSIONS REFER TO CASTING NOTES MACHINING "ROUGH" TO ISO 2768-VL MACHINING "STD." TO ISO 2768-mk POLYURETHANE: ±2.0 WELD SYMBOLS: IN ACCORDANCE TO ISO 2553 MACHINED SURFACES UNO: TO BE $\sqrt{\text{R}}$ WHERE INDICATED "ROUGH" TO BE $\sqrt{\text{S}}$ WHERE NOT INDICATED	MATERIAL: N/A FINISH: N/A COLOUR: N/A MFG'D: INTERNAL SCALE: DO NOT SCALE	DRAWN BY: JS CHECKED: APPROVED: CREATED: 16/04/2026	DESCRIPTION: MUS3 - BT - SPARE PARTS PART NO.:	PROFILE CUT ITEMS: TO BE CUT FROM SUPPLIED DXF CAD FILE WHERE APPLICABLE. ADDITIONAL DIMENSIONS CAN BE PROVIDED ON REQUEST DO NOT SCALE IF IN DOUBT © COPYRIGHT. ALL RIGHTS RESERVED <small>THIS DRAWING IS STRICTLY CONFIDENTIAL AND MUST NOT BE COPIED, REPRODUCED OR ADAPTED, NOR MAY ARTICLES BE MANUFACTURED IN ACCORDANCE WITH THE DRAWING WITHOUT PRIOR WRITTEN PERMISSION OF MATO AUSTRALIA PTY LTD.</small>		<small>MATO AUSTRALIA PTY LTD (INCORPORATED IN NEW SOUTH WALES) 33 BONDVILLE AVE BRANTFORD NSW 2122 PH: 1800 850 755 FAX: (02)4556 1388</small>	
REV.	DESCRIPTION	BY	APRVD	DATE							
A	ISSUED FOR INFORMATION	JS		14/02/2025	MASS:	47.05 KG	DRAWING NO.		PG. SIZE	SHEET	REV
								A3	1 / 1	A	

C:\Mato\Auto\Auto\Production\REV\COL DER STRUCTURE\SECONDARY\CLEANER\MUS3\BOLT_TENSION\1201_10_07\CAD\FLESH\20141.DWG