

MDP235 CS2 Primary Cleaner Installation, Operation and Maintenance Manual

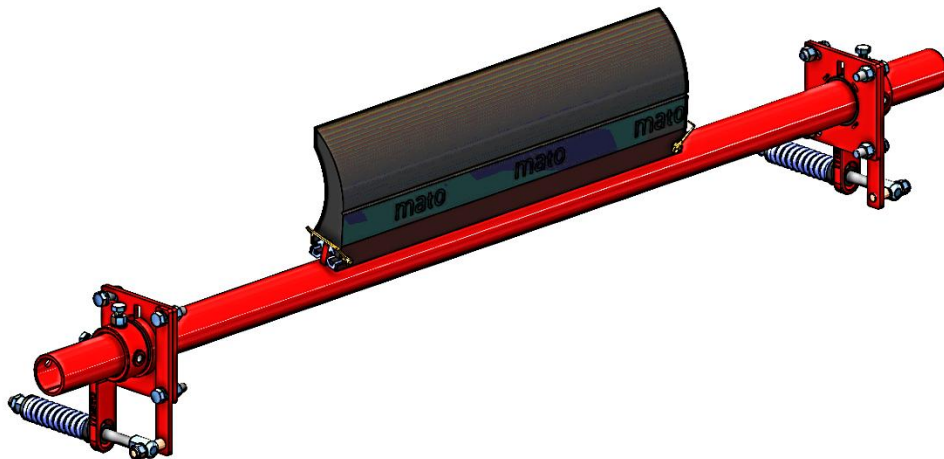

Purchase Date: _____

Purchased From: _____

Installation Date: _____

This information will be helpful for any future inquiries or questions about belt cleaner replacement parts, specifications or troubleshooting.

Contents

- Section 1 – Important Information 4**
 - 1.1 General Introduction 4
 - 1.2 User Benefits 5
 - 1.3 Service Option 5
- Section 2 – Safety Considerations and Precautions 5**
 - 2.1 Stationary Conveyors 5
 - 2.2 Operating Conveyors..... 7
- Section 3 – Pre-installation Checks and Verifications..... 8**
 - 3.1 Checklist 8
- Section 4 – Installation Instructions..... 9**
 - 4.1 MDP235 CS1 Cleaner – Chute Mounting 10
 - 4.2 Cleaner X, Y Locations Modifications (If required)..... 11
 - 4.3 Installing MDP235 CS2..... 13
- Section 5 - Trouble shooting..... 16**
- Section 6 - Maintenance 17**
 - 6.1 New Installation Inspection 17
 - 6.2 Visually inspect belt cleaner on a regular basis..... 17
 - 6.3 Routine Physical Inspection/adjustments 18
 - 6.4 Spare Parts and Specifications..... 18
- Section 7 - MDP235 CS1 Specifications: 18**

Section 1 – Important Information

1.1 General Introduction

This manual is intended to help you understand how this product operates and to assist you in achieving maximum efficiency throughout its service life. For the product to function safely and effectively, it is important that the information and guidelines provided are fully understood and followed. Within this manual you will find safety precautions, installation instructions, maintenance procedures, and troubleshooting guidance. If you encounter questions or issues not addressed here, please visit our website or contact our Customer Service Department.

Please review this manual carefully and ensure it is provided to anyone who will be directly involved in the installation, operation, or maintenance of this cleaner. Although the installation and servicing procedures have been designed to be as straightforward as possible, proper installation along with routine inspections and maintenance are still necessary to keep the cleaner operating at peak performance.

Customer Service:

Australia/South-East Asia

MATO Australia Pty Ltd.
Tel: +61 1300 850 795
maus@mato.com.au

United Kingdom

MATO Industries Ltd
Tel: +44 (0) 1254 3876 38
info@mato.co.uk

South Africa

MATO Products Pty Ltd.
Tel: +27 (0) 1192 3602 4
matosales@multotec.co.za

China

MATO Industrial Technology
Tel: +86 5374 5337 99
info@mato.com.cn

North America

MATO Corp
Tel: +1(1) 3042 551280
info@mato-usa.com

South America

MATO LATAM
Tel: +57 3173 6207 51
csouto@mato.latam.com

Germany - Europe

MATO GmbH & Co Kg
Tel: +49 (0) 6108 906 0
beltlacing@mato.de

Visit www.mato.com.au for other MATO locations and products.

1.2 User Benefits

Proper installation along with consistent maintenance can deliver the following advantages for your operation:

- Decreased conveyor downtime
- Reduced labour hours
- Lower overall maintenance budget requirements
- Extended service life for the belt cleaner and other conveyor components

1.3 Service Option

The MDP235 Cleaner is engineered for straightforward installation and servicing by your onsite personnel. If you would rather have full turn-key factory service, please reach out to your local MATO Field Representative.

Section 2 – Safety Considerations and Precautions

Before installing or operating the MDP235 Cleaner, it is essential to review and understand the safety information provided. Various set-ups, maintenance, operational tasks involve contact with stationary and operating conveyors. Each situation requires adherence to its specific safety protocol.

2.1 Stationary Conveyors

The following tasks are carried out when the conveyor is stationary and isolated:

- Installation
- Blade replacement
- Repairs
- Tension adjustments
- Cleaning

DANGER

It is essential that all Lockout/Tagout regulations are followed before performing any of the above activities. Not applying Lockout/Tagout procedures exposes personnel to unexpected movement of the conveyor belt, which can cause uncontrolled action of the belt cleaner. Serious injury or fatal consequences may result.

Before working:

- Lockout/Tagout the conveyor power source
- Follow site regulations/instructions for belt maintenance
- ensure work site is safe to carry out work

WARNING

Use Personal Protective Equipment (PPE):

(as per site requirements)

- Safety eyewear
- Hardhats
- Safety footwear
- Safety gloves

Close quarters, springs and heavy components create a worksite that compromises a worker's eyes, feet and skull. PPE must be worn to control the foreseeable hazards associated with conveyor belt cleaners. Serious injuries can be avoided.

2.2 Operating Conveyors

There are two routine tasks that must be performed while the conveyor is running:

- Inspection of the cleaning performance
- Dynamic troubleshooting

DANGER

Every belt cleaner presents an in-running nip hazard. Never touch or interfere with a cleaner while it is in operation. Hazards associated with an operating cleaner can result in immediate amputation or entrapment. Do not attempt to make any adjustments while the cleaner is running.

WARNING

Unexpected belt tears or projections may catch on the cleaner, causing sudden and forceful movement of the cleaner assembly. Loose or flailing components can lead to severe injury or death.

WARNING

Belt cleaners can also become projectile hazards. Maintain as much distance from the cleaner as reasonably possible and always wear appropriate PPE. Flying debris can cause serious harm.

Section 3 – Pre-installation Checks and Verifications

3.1 Checklist

- Verify that the cleaner size matches the belt width
- Inspect the belt cleaner carton to confirm all required parts are present
- Review the “Tools Needed” list at the top of the installation instructions
- Inspect the conveyor site:
 - Ensure the conveyor being serviced, along with any upstream/downstream conveyors, is fully isolated in accordance with regulatory and site procedures
 - Determine whether the cleaner will be installed on a chute
 - Identify if the installation is on an open head pulley that will require mounting structure
 - Check for any obstructions that may necessitate adjustments to the cleaner’s location
 - Carry out a complete risk assessment and safe method statement as required by site standards for the work area, and prepare a job plan based on the instructions provided here

Note:

That the installation instructions provided should be regarded as typical guidelines and recommendations. These installation instructions may not fully reflect site conditions and/or safety requirements.

Section 4 – Installation Instructions

MDP235 CS2 Cleaner

MDP235 CS2 - MOUNTING

Tools required:

- Rule
- Tape measure
- Marking pen
- Level
- 15/16" (24mm) spanner
- Pinch bar

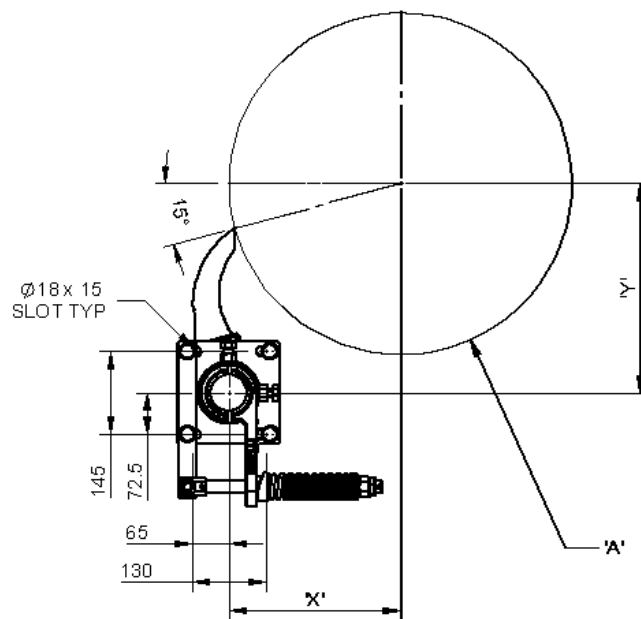

***Physically lock out and tag the conveyor at the power source
before you begin cleaner installation.***

4.1 MDP235 CS2 Cleaner – Chute Mounting

Installation specifications and instructions are based on the assumption that the conveyor is in its working position (angle). If the conveyor angle will be different, the cleaner mounting brackets should be installed per the final position, parallel to conveyor structure.

1. Locating correct shaft position. Measure and determine Dimension A. Find Dimension A on the Shaft Location Chart (refer to fig.1) and determine Dimensions X, Y and C.
2. Measure out from the centre of pulley shaft parallel with ground level, mark out 'X' dimension. From 'X' dimension, draw a line down perpendicular with ground line, then measure and mark out dimension 'Y' (refer to fig.2). This indicates the location of the centre of the cleaner shaft. Measure and mark out both sides of pulley.

Pulley Diameter = _____ mm; X = _____ mm; Y = _____ mm; C = _____

Using the correct X and Y coordinates will position the cleaner at 15° below the centre line of the pulley (centre line parallel with ground level) on the head pulley.

fig. 1

A = Pulley Diameter + Lagging and Belt
C = Critical Spec. if there is any obstruction in proposed X, Y location.
X, Y measurements can be modified. C is required to remain the same

Shaft Location Chart

A	X	Y	C
400	138	337	364
425	152	340	372
450	165	344	381
475	179	347	390
500	192	351	400
525	205	354	409
550	218	357	419
575	231	361	428
600	244	364	438
625	256	367	448
650	269	371	458
675	282	374	468
700	295	377	478
725	307	381	489
750	320	384	500
775	332	387	510
800	345	391	521
825	357	394	532
850	370	397	543
875	382	400	554
900	395	404	565
925	407	407	576
950	419	410	587
975	432	414	598
1000	444	417	609

Note:
If modifications are required to 'X' and 'Y' dimensions due to obstruction in existing structure, please refer to page 11.

4.2 Cleaner X, Y Locations Modifications (If required)

In certain installations, it may be required to adjust the location of a primary cleaner shaft due to structural obstructions that prevent installation at the recommended position. The shaft location can be relocated without affecting cleaner performance, provided the critical "C" dimension is maintained.

1. Determine Required Modification

Mark out the existing X and Y dimensions as per shaft location chart (fig.1 pg. 10). Identify the amount of relocation required to provide sufficient clearance for the shaft and tensioning assembly. For an example if we determine the 'Y' dimension needs to be lowered by 25mm to clear all structure, we now have 2 dimensions out of 3 required to locate shaft. ('C' and 'Y' are known and 'X' is to be calculated).

2. Calculate the New X Dimension

From centre of pulley draw a vertical line down and horizontal line across (fig. 2). Measure down from the intersection the newly determined 'Y' dimension and mark (fig. 3). From this new Y reference point, measure diagonally across toward the horizontal line using the fixed 'C' dimension, mark where it intersects the horizontal line (fig. 4). Measure from the original intersection point along the horizontal line to this new intersection. This measurement is the revised X dimension (fig. 5).

Example

If we use a pulley size of 250 ('A') 'X' = 118mm, 'Y' = 180mm, 'C' = 215mm and we determine that 'Y' needs to be lowered by 25mm. we know 'Y' = 205mm, 'C' = 215mm and 'X' = unknown

By following these steps, in this example we can determine that 'X' = 65mm

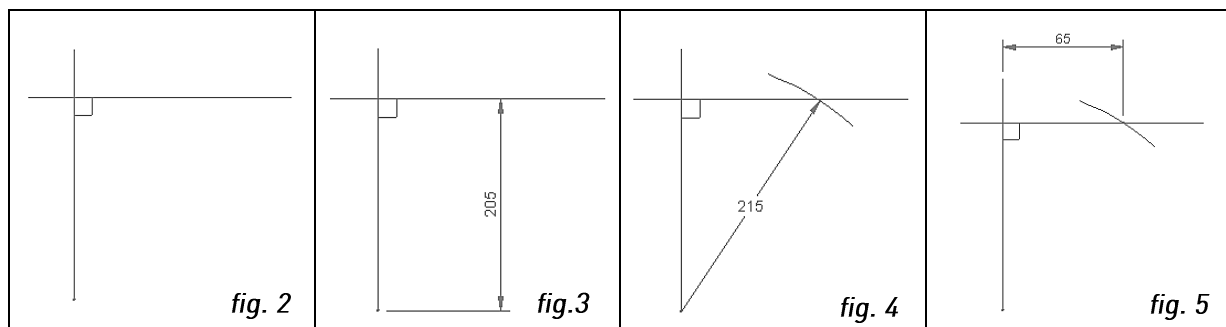

3. Mark out and trace mounting template. Using the mounting template provided (as shown in fig. 6) in the instruction packet, position the shaft access hole on the chute aligned with 'X' and 'Y' coordinates. Trace the shaft cut-out and mounting slotted holes. Repeat on opposite side of pulley.

NOTE: Hole cut outs are slotted for later adjustment if needed.

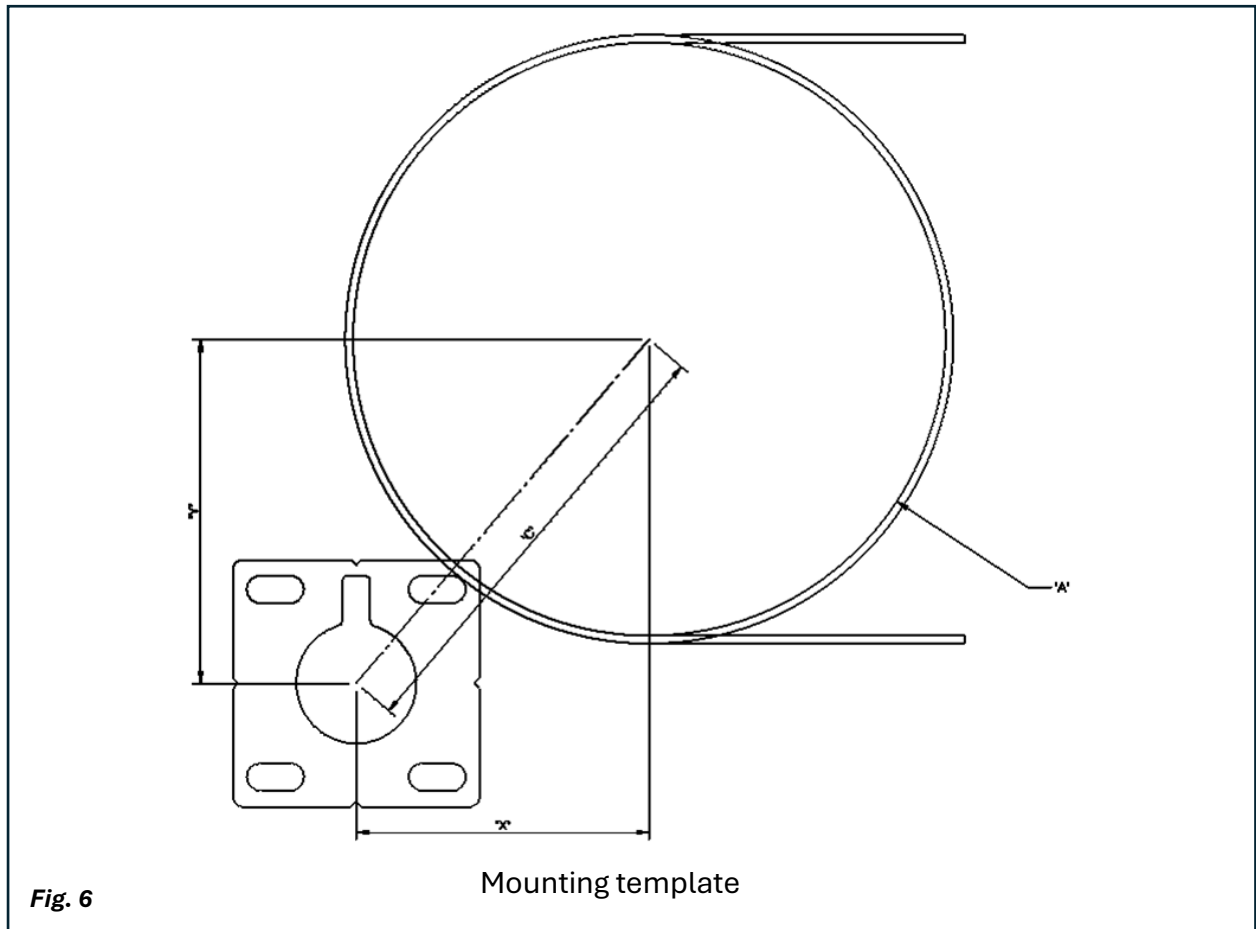

Example of locating mounting plate template parallel with belt feed line

4.3 Installing MDP235 CS2

- 1- Bolt the mounting brackets along with torque arm to the drilled-out holes on chute or conveyor structure using supplied fasteners.
(fig 7)

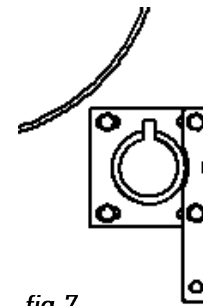

fig 7

- 2- Insert shaft through mounting blocks to opposite side.
(fig 8)

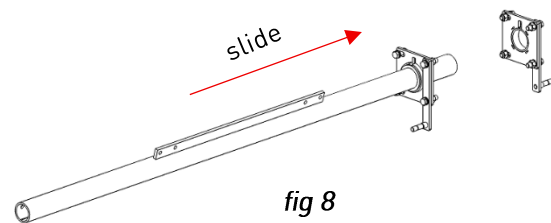

fig 8

- 3- Position shaft centre to pulley loosely and install pivot bushes.
(fig 9)

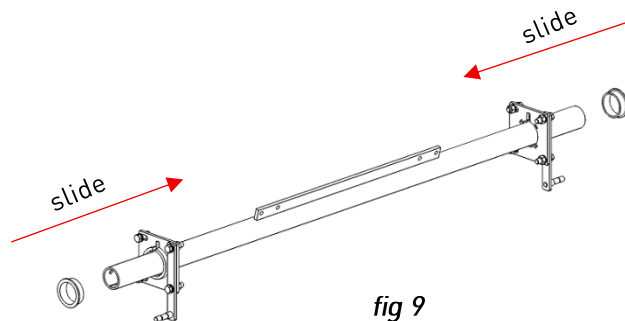

fig 9

- 4- Install tensioning assembly.
Torsion arm will fit snug against pivot bush,
bolts on the torsion arm, are to remain loose.
Confirm shaft centre to pulley
(fig 10)

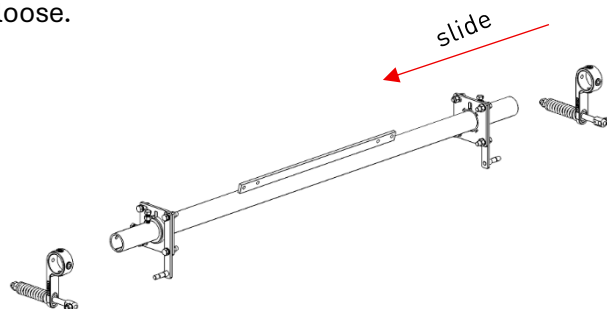

fig 10

- 5- Install blade and retaining pins to shaft, confirm shaft is centre to pulley.
(fig 11, fig 12)

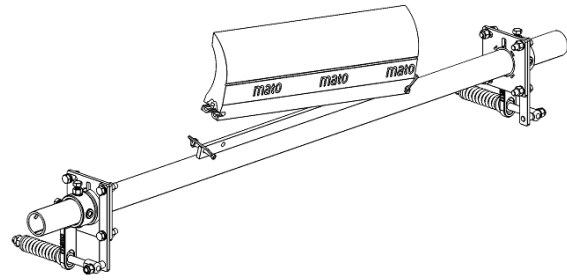

fig 11

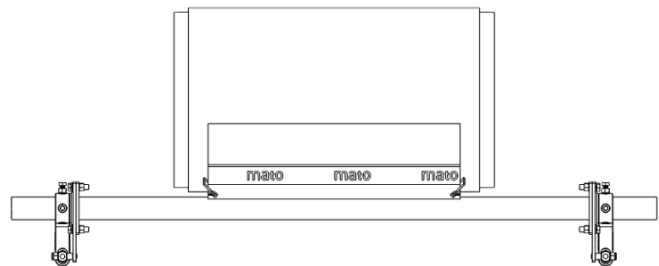

fig 12

- 6- Rotate shaft up to have blade point rest against pulley. Tighten torque clamp bolts to shaft to hold shaft in correct Position.
(fig 13, fig 14)

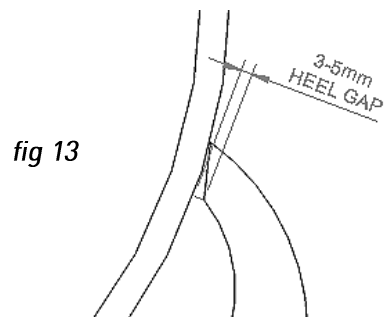

fig 13

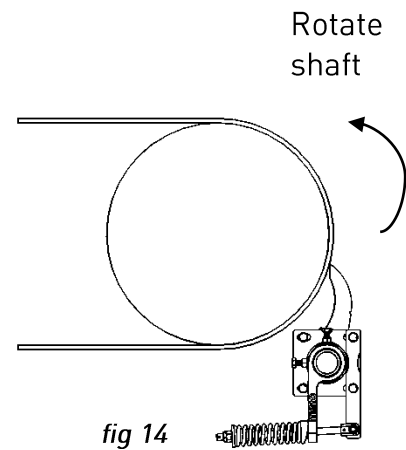

fig 14

7- Setting blade tension

Once tensioning assembly is installed to cleaner use the spring tensioning chart (fig.15) to set blade tension to belt.

(note measurement to be taken of spring compression, do not include bushings)

MDP235 CS2 SPRING TENISONING CHART

BLADE WIDTH	SILVER SPRING	YELLOW SPRING
mm	mm	mm
450	146	
600	144	
650	142	
750	140	
850	138	
900	136	
1050	134	
1250		135
1350		133
1450		131
1650		129
1850		127
1950		125
2250		123

fig.15

8- Test run conveyor and inspect cleaner performance.

Run conveyor for 15minutes to determine if there is excess vibration and efficiency of cleaner.

Section 5 - Trouble shooting

Problem	Possible Cause	Possible Solution
Poor cleaning performance	Cleaner under-tensioned	Adjust to correct tensions – see spring compression chart
	Cleaner over-tensioned	
	Cleaner blade worn or damaged	Verify 'X, Y and C' dimensions, relocate to correct dimensions Replace Blade
Rapid blade wear	Tension on cleaner too high/low	Adjust to correct tension – see spring compression chart
	Cleaner not located correctly	Check cleaner location for correct dimensions Verify blade heel gap 3-5mm, adjust 'X, Y' dimensions, adjust to create correct heel gap
	Blade attack angle incorrect	
	Material too abrasive for the blade	Option: switch to cleaner with tungsten blades or replace blade with greater PU Install spray bar
	Mechanical splice damaging blade	Repair, skive or replace splice
Centre wear on blade (smile effect)	Blade wider than material path	Replace blade width to match material path
	Tension on cleaner too high/low	Adjust to correct tensions – see spring compression chart
Unusual wear or damage to blade	Mechanical splice damaging the blade	Repair, skive or replace splice
	Belt damaged or ripped	Repair or replace belt
	Cleaner not correctly located	Verify 'X, Y and C' dimensions, relocate to correct dimensions
	Damage to pulley or pulley lagging	Repair or replace pulley
Vibration or noise	Cleaner not located correctly	Verify blade heel gap 3-5mm, adjust 'X, Y and C' dimensions, relocate to correct dimensions
	Blade attack angle incorrect	
	Cleaner running on empty belt	Use spray bar when belt is empty Belt is empty or dry
	Cleaner tension too high/low	Adjust to correct tension or slight adjust to diminish
	Cleaner not square to head pulley	Verify 'X, Y and C' dimensions, relocate to correct dimensions
	Material build up in chute	Clean build up off cleaner and chute
	Cleaner locking bolts not secure	Check and tighten all bolts and nuts
Cleaner being pushed away from pulley	Cleaner tension not set correctly	Ensure correct tension/increase tension slightly
	Stocky material is overburdening	Increase tension; replace with cleaner with metal tips; replace with larger cleaner
	Cleaner not set up correctly	Confirm location dimensions are equal on both sides

Section 6 - Maintenance

MATO belt cleaners are built to function with minimal attention; some servicing is still necessary to keep performance at a high level. Once the cleaner has been installed, a routine maintenance schedule should be established. Following such a schedule helps ensure the cleaner continues to run at peak efficiency and allows potential issues to be detected and resolved before the cleaner fails.

All safety requirements for inspecting the equipment—whether stationary or in operation—must be followed. The MDP235 cleaner operates at the conveyor's discharge end and remains in direct contact with the moving belt. While the belt is in motion, only visual checks are permitted. Any service activities must be carried out only when the conveyor is shut down, and proper lockout/tagout procedures must be strictly observed.

6.1 New Installation Inspection

After the cleaner has been operating for several days, carry out a visual review to confirm that it is functioning correctly. Make any required adjustments at this time.

6.2 Visually inspect belt cleaner on a regular basis

A periodic visual check of both the cleaner and the belt can indicate:

- Whether the spring length matches the specification needed for proper tensioning
- Whether the belt surface appears clean or shows sections with material build up
- Whether the blade shows excessive wear and should be replaced
- Whether the blade or any other cleaner components show signs of damage
- Whether fugitive material has accumulated on the cleaner or within the transfer area
- Whether there is any belt cover damage
- Whether the cleaner is vibrating or bouncing on the belt
- If a snub pulley is installed, whether there is material build up on the pulley

If any of these conditions are present, decide when the conveyor can be safely shut down to perform cleaner maintenance.

6.3 Routine Physical Inspection/adjustments

With the conveyor fully stopped and properly locked and tagged out, conduct a hands-on inspection of the cleaner, including the following tasks:

- Remove any material build up from the cleaner blade and shaft
- Examine the blade closely for wear or damage and replace it if necessary
- Inspect both blade pins and retaining clips to confirm correct installation and condition; replace if required
- Verify that the blade maintains full contact with the belt
- Check the cleaner shaft for any signs of damage
- Inspect all fasteners for tightness and wear; tighten or replace where needed
- Replace any cleaner components that are worn or damaged
- Check the blade-to-belt tension and adjust it if needed using the chart on the cleaner or the chart on Page 15
- After all maintenance steps are completed, run the conveyor to confirm the cleaner is functioning as expected

6.4 Spare Parts and Specifications

The MDP235 CS2 cleaner – the Mato Drop on Primary cleaner is the simplest primary cleaner available on the market, with its easy tension spring application for constant tensioning and reduced adjustability. Quick and easy blade replacement by removing the blade locking pins is simple. The MDP235 range of polyurethane primary cleaners are manufactured with a unique self-lubricating blade to reduce friction and blade wear.

Section 7 - MDP235 CS2 Specifications:

- Blade lengths available in minus 150mm and 300mm blade widths
- MDP235 cleaners are supplied with a singlet tensioned end assembly
- Belt speeds up to 5.0m/s
- Suits pulleys diameters from 400mm – 1000mm
- Suitable for reversing conveyors
- Blade material 85A shore
- Temperature rated -35°C – 82°C
- Suitable for conveyors fitted with mechanical fasteners

