

- ASSEMBLY NOTES:
1. UNLESS DRAWINGS ARE MARKED "FOR CONSTRUCTION", THEY SHALL NOT BE USED FOR CONSTRUCTION PURPOSES
 2. DO NOT OBTAIN DIMENSIONS BY SCALING FROM DRAWING
 3. REMOVE ALL BURRS AND SHARP EDGES
 4. ALL CUTS TO BE A MINIMUM OF CLASS 2 $\sqrt{3.2}$ FINISH UNO

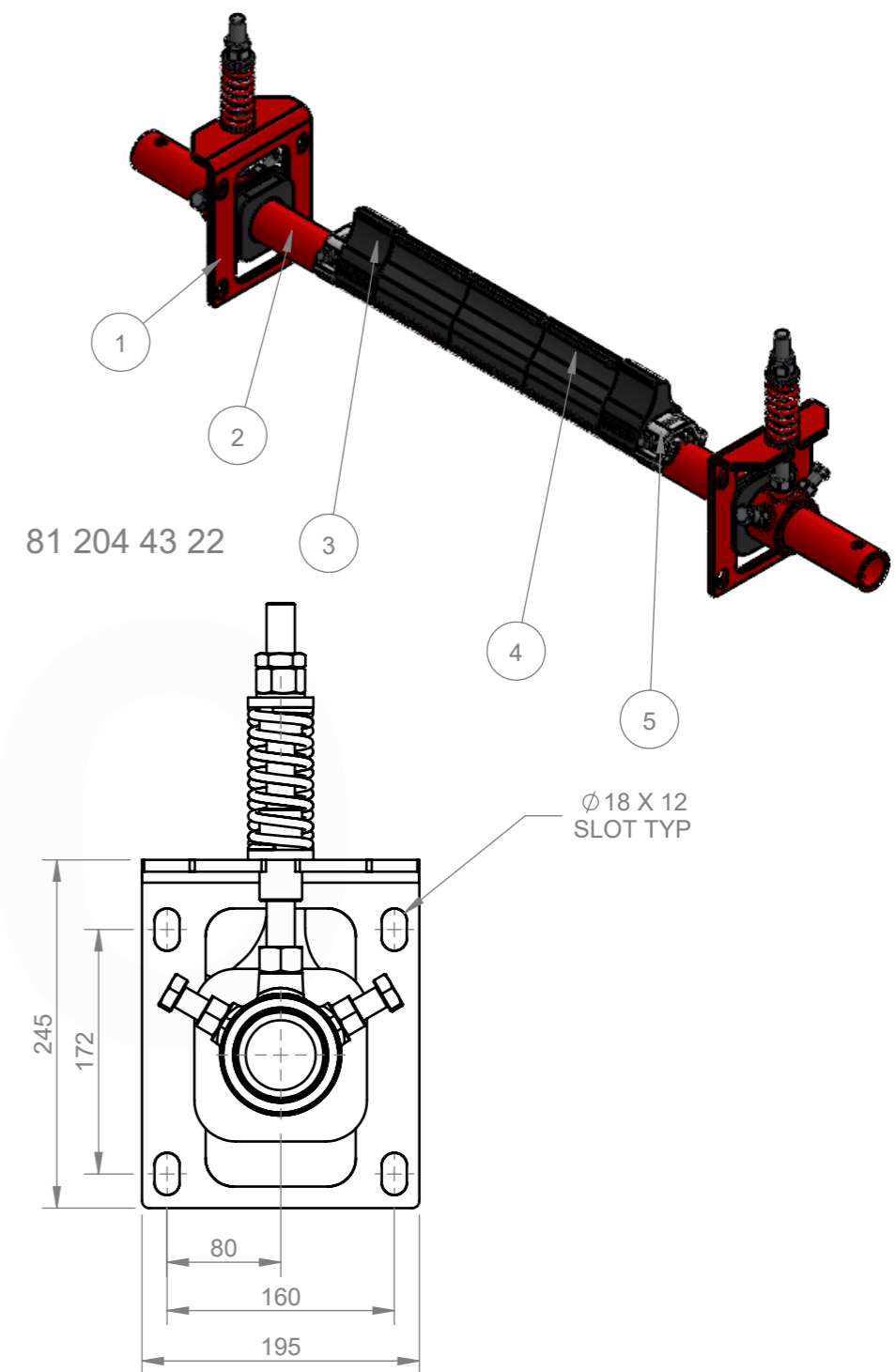
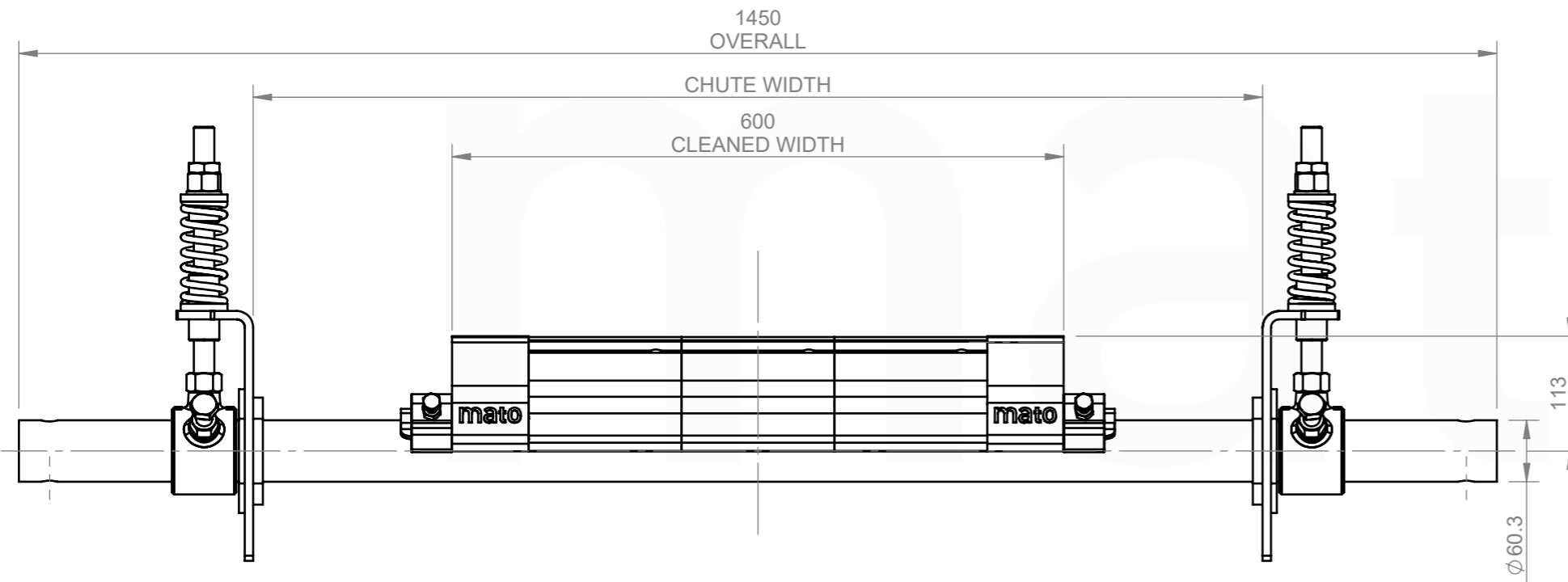

ITEM NO.	DESCRIPTION	QTY.	PART NO.	MASS K/G
1	60.3mm CS END ASSEMBLY - POWDERCOATED RED (RED SPRING)	1	81 264 00 60	10.46
2	MUS SHAFT SUITS 600mm	1	81 200 21 02	12.65
3	MUS3 POLY END BLADE, 75mm	2	81 240 00 06	0.52
4	MUS3 TI BLADE/CUSHION 45 DURO STAINLESS STEEL	3	82 240 00 02	1.09
5	MUS2,3 & 4 END STOP	2	81 240 00 07	0.56

CHUTE CUT OUT DETAIL:
REFER TO CUT OUT TEMPLATE
MUS3 INSTALLATION TEMPLATE

<p>REVISIONS</p> <table border="1"> <thead> <tr> <th>REV.</th> <th>DESCRIPTION</th> <th>BY</th> <th>APR'VD</th> <th>DATE</th> </tr> </thead> <tbody> <tr> <td>A</td> <td>ISSUED FOR CONSTRUCTION</td> <td>KD</td> <td>JS</td> <td>22/10/25</td> </tr> </tbody> </table>					REV.	DESCRIPTION	BY	APR'VD	DATE	A	ISSUED FOR CONSTRUCTION	KD	JS	22/10/25	<p>MACHINING AND FABRICATION TOLERANCES UNO: (ALL DIMENSIONS IN mm)</p> <p>PIPE STRAIGHTNESS: X.X ±1.0, X.XX ±0.5, X.XXX ±0.1, X.XXXX ±0.01</p> <p>HOLE CENTERS: X.X ±1.0°, X.XX ±0.5°</p> <p>THERMAL CUTTING: ±1.0, WELDMENTS: ±2.0</p> <p>CASTINGS: REFER TO CASTING NOTES</p> <p>MACHINING 'ROUGH' TO ISO 2768-vL</p> <p>MACHINING STD: TO ISO 2768-mK</p> <p>POLYURETHANE: ±2.0</p> <p>WELD SYMBOLS: IN ACCORDANCE TO ISO 2553</p> <p>MACHINED SURFACES UNO: TO BE $\sqrt{3.2}$ WHERE INDICATED 'ROUGH' TO BE $\sqrt{3.2}$ WHERE NOT INDICATED</p>		<p>MATERIAL: N/A</p> <p>FINISH: N/A</p> <p>COLOUR: N/A</p> <p>MFG'D: INTERNAL</p> <p>SCALE: DO NOT SCALE</p>		<p>DRAWN BY: KD</p> <p>CHECKED: JS 22/10/25</p> <p>APPROVED: JS 22/10/25</p> <p>CREATED: 22/10/2025</p>		<p>DESCRIPTION: MUS3-TI-65-CS-600</p> <p>PART NO.: 81 204 43 22</p> <p>MASS: 28.56 KG</p>		<p>PROFILE CUT ITEMS: TO BE CUT FROM SUPPLIED DXF CAD FILE WHERE APPLICABLE. ADDITIONAL DIMENSIONS CAN BE PROVIDED ON REQUEST. DO NOT SCALE IF IN DOUBT.</p> <p>© COPYRIGHT. ALL RIGHTS RESERVED</p> <p>THIS DRAWING IS STRICTLY CONFIDENTIAL AND MUST NOT BE COPIED, REPRODUCED OR ADAPTED, NOR MAY ARTICLES BE MANUFACTURED IN ACCORDANCE WITH THE DRAWING WITHOUT PRIOR WRITTEN PERMISSION OF MATO AUSTRALIA PTY LTD.</p>		<p>mato</p> <p>MATO AUSTRALIA PTY LTD (INCORPORATED IN NSW) ABN 62 050 057 726</p> <p>39 BONVILLE AVE THORNTON NSW 2322 PH: 1300 850 795 FAX: (02)4936 1388</p>		<p>DRAWING NO.: 8382</p> <p>PG. SIZE: A3</p> <p>SHEET: 1 / 1</p> <p>REV: A</p>	
					REV.	DESCRIPTION	BY	APR'VD	DATE																			
A	ISSUED FOR CONSTRUCTION	KD	JS	22/10/25																								
							<p>3RD ANGLE PROJECTION</p>																					

C:\Manufact\01-Production\NEW FOLDER STRUCTURE\SECONDARY CLEANERS\MUS3\COMPRESSION SPRINGS\1 204 43 22\CAD FILES\81 204 43 22