

- ASSEMBLY NOTES:
1. UNLESS DRAWINGS ARE MARKED "FOR CONSTRUCTION", THEY SHALL NOT BE USED FOR CONSTRUCTION PURPOSES
 2. DO NOT OBTAIN DIMENSIONS BY SCALING FROM DRAWING
 3. REMOVE ALL BURRS AND SHARP EDGES
 4. ALL CUTS TO BE A MINIMUM OF CLASS 2 $\sqrt{3.2}$ FINISH UNO

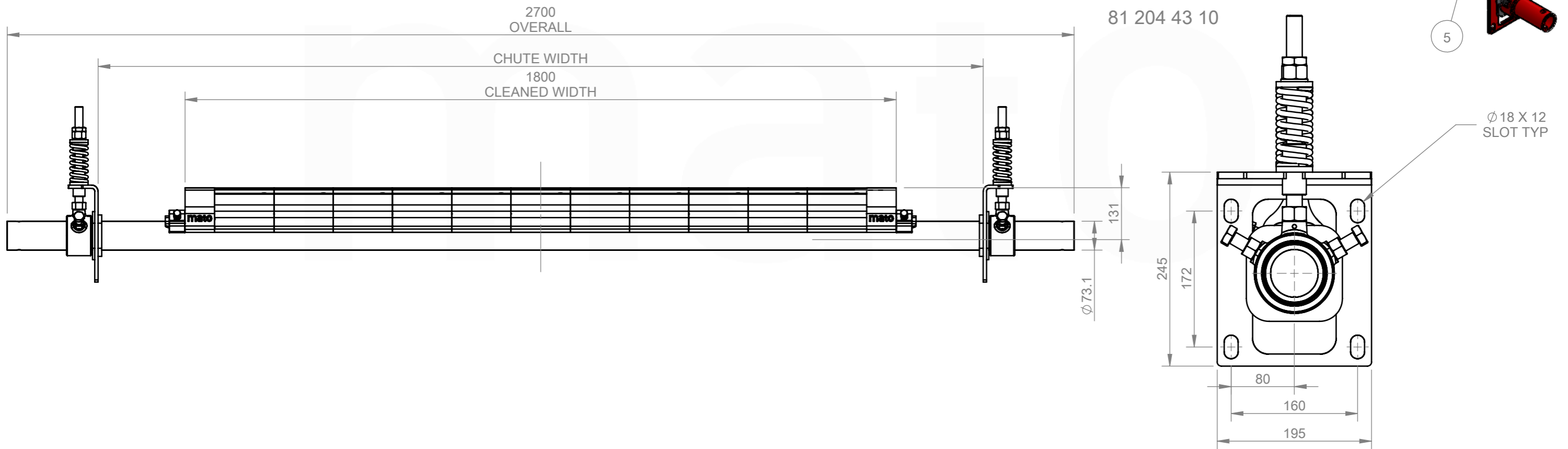

ITEM NO.	DESCRIPTION	QTY.	PART NO.	MASS K/G
1	73.0mm CS 60.3mm CS END ASSEMBLY - POWDERCOATED RED (SILVER SPRING)	1	81 264 00 75	10.85
2	MUS SHAFT SUITS 1800mm	1	81 200 21 10	33.40
3	MUS3 POLY END BLADE, 75mm	2	81 240 00 06	0.52
4	MUS3 TI BLADE/CUSHION 45 DURO STAINLESS STEEL	11	82 240 00 02	1.09
5	MUS2,3 & 4 END STOP	2	81 240 00 07	0.56

CHUTE CUT OUT DETAIL:
REFER TO CUT OUT TEMPLATE
MUS3 INSTALLATION TEMPLATE

<p>REVISIONS</p> <table border="1"> <thead> <tr> <th>REV.</th> <th>DESCRIPTION</th> <th>BY</th> <th>APRVD</th> <th>DATE</th> </tr> </thead> <tbody> <tr> <td>A</td> <td>ISSUED FOR CONSTRUCTION</td> <td>KD</td> <td>JS</td> <td>22/10/25</td> </tr> </tbody> </table>					REV.	DESCRIPTION	BY	APRVD	DATE	A	ISSUED FOR CONSTRUCTION	KD	JS	22/10/25	<p>MACHINING AND FABRICATION TOLERANCES UNO: (ALL DIMENSIONS IN mm)</p> <p>DIMENSIONAL TOLERANCE: PIPE STRAIGHTNESS</p> <p>X.X ±1.0 <1000 ±3.0</p> <p>X.XX ±0.5 <2000 ±6.0</p> <p>X.XXX ±0.1 <3000 ±9.0</p> <p>X.XXXX ±0.01</p> <p>ANGLE: ±1.0°</p> <p>X.X ±0.5°</p> <p>X.XX ±0.5°</p> <p>HOLE CENTERS: ±0.5</p> <p>THERMAL CUTTING: ±1.0</p> <p>WELDMENTS: ±2.0</p> <p>CASTINGS: REFER TO CASTING NOTES</p> <p>MACHINING "ROUGH" TO ISO 2768-vL</p> <p>MACHINING STD: TO ISO 2768-mK</p> <p>POLYURETHANE: ±2.0</p> <p>WELD SYMBOLS: IN ACCORDANCE TO ISO 2553</p> <p>MACHINED SURFACES UNO:</p> <p>TO BE $\sqrt{12.5}$ WHERE INDICATED "ROUGH"</p> <p>TO BE $\sqrt{3.2}$ WHERE NOT INDICATED</p>		<p>MATERIAL: N/A</p> <p>FINISH: N/A</p> <p>COLOUR: N/A</p> <p>MFG'D: INTERNAL</p> <p>SCALE: DO NOT SCALE</p>		<p>DRAWN BY: KD</p> <p>CHECKED: JS 22/10/25</p> <p>APPROVED: JS 22/10/25</p> <p>CREATED: 22/10/2025</p>		<p>DESCRIPTION: MUS3-TI-45-CS-1800</p> <p>PART NO.: 81 204 43 10</p> <p>MASS: 58.47 KG</p>		<p>PROFILE CUT ITEMS: TO BE CUT FROM SUPPLIED DXF CAD FILE WHERE APPLICABLE. ADDITIONAL DIMENSIONS CAN BE PROVIDED ON REQUEST. DO NOT SCALE IF IN DOUBT.</p> <p>© COPYRIGHT. ALL RIGHTS RESERVED.</p> <p>THIS DRAWING IS STRICTLY CONFIDENTIAL AND MUST NOT BE COPIED, REPRODUCED OR ADAPTED, NOR MAY ARTICLES BE MANUFACTURED IN ACCORDANCE WITH THE DRAWING WITHOUT PRIOR WRITTEN PERMISSION OF MATO AUSTRALIA PTY LTD.</p>		<p>mato</p> <p>MATO AUSTRALIA PTY LTD (INCORPORATED IN NSW) ABN 82 050 057 726</p> <p>39 BONVILLE AVE THORNTON NSW 2322 PH: 1300 850 795 FAX: (02)4936 1388</p>	
					REV.	DESCRIPTION	BY	APRVD	DATE																	
A	ISSUED FOR CONSTRUCTION	KD	JS	22/10/25																						
<p>DRAWING NO.: 8379</p> <p>PG. SIZE: A3</p> <p>SHEET: 1 / 1</p> <p>REV: A</p>		<p>3RD ANGLE PROJECTION</p>																								

C:\Mat\Mat\Mat\Mat\Production\NEW FOLDER STRUCTURE\SECONDARY CLEANERS\MUS3\COMPRESSOR SPRING\91 204 43 10