

ASSEMBLY NOTES:

1. UNLESS DIMENSIONS ARE MARKED "FOR CONSTRUCTION", THEY SHALL NOT BE USED FOR CONSTRUCTION PURPOSES
2. DO NOT OBTAIN DIMENSIONS BY SCALING FROM DRAWING
3. REMOVE ALL BURRS AND SHARP EDGES
4. ALL CUTS TO BE A MINIMUM OF CLASS 2  $\sqrt{3.2}$  FINISH UNO

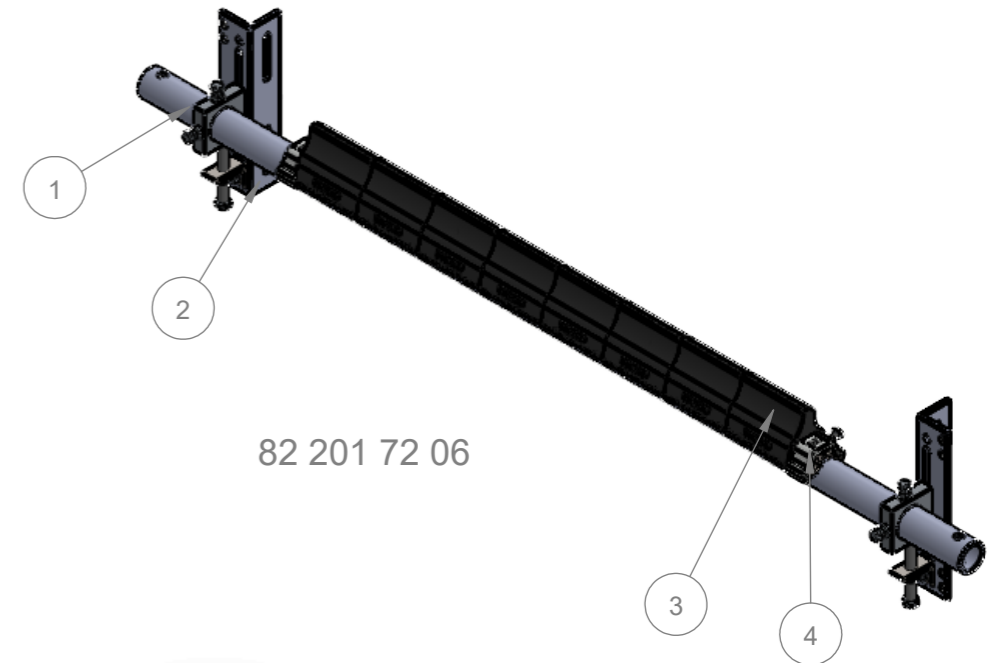

82 201 72 06

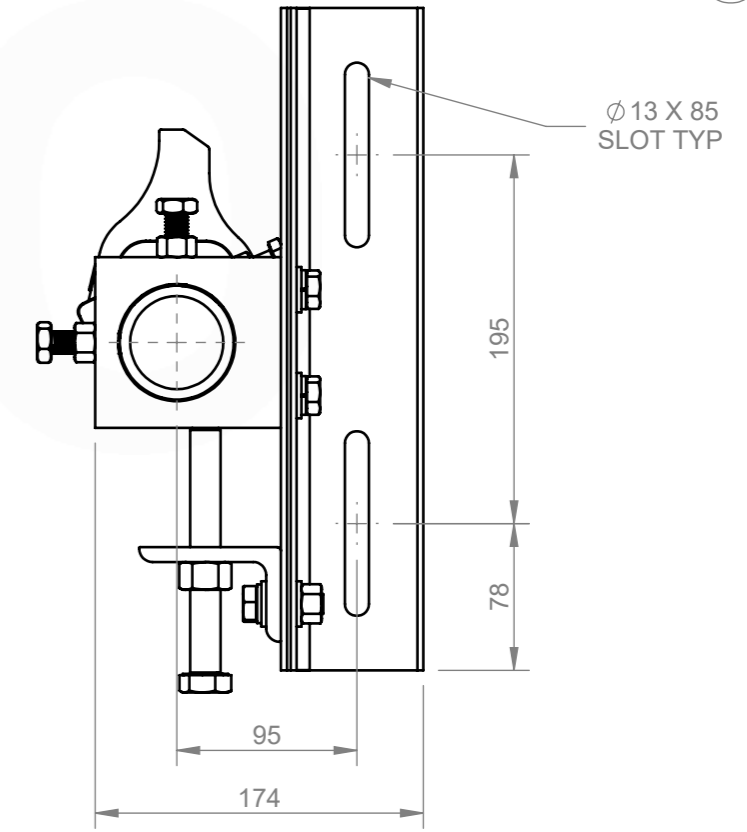
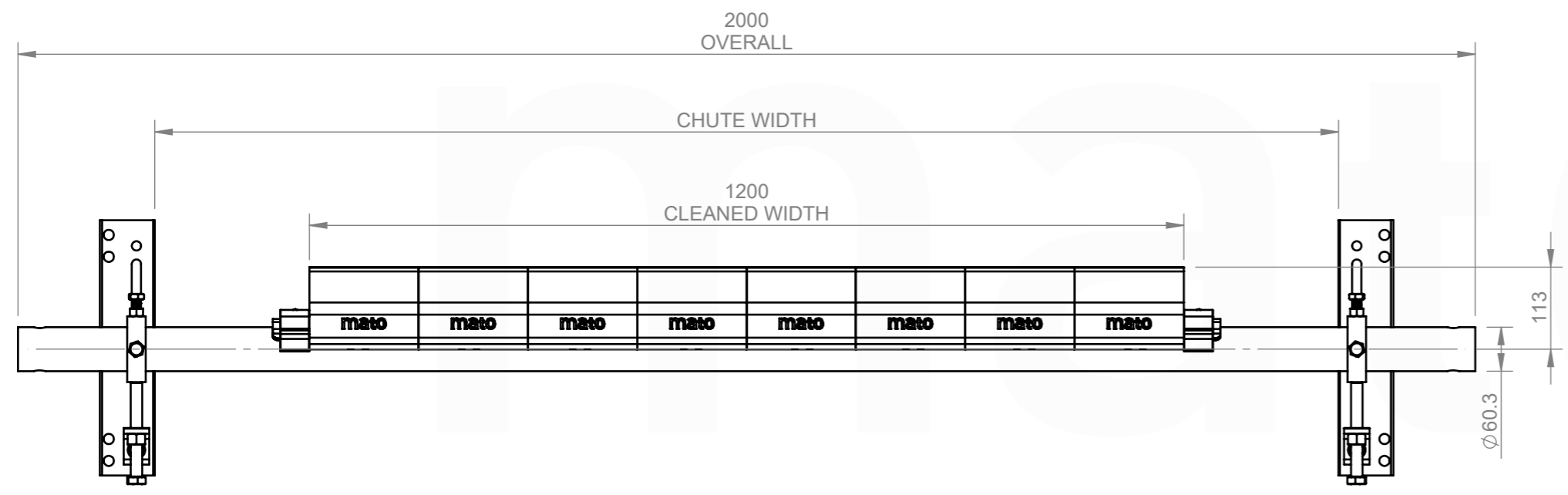

CHUTE CUT OUT DETAIL:  
REFER TO CUT OUT TEMPLATE  
MUS3 BT INSTALLATION TEMPLATE

ITEM NO.	DESCRIPTION	QTY.	PART No.	MASS k/g
1	MUS Shaft suits 1200mm STAINLESS STEEL	1	82 200 21 06	18.75
2	60.3 MCS2 BT END ASSEMBLY STAINLESS STEEL	1	82 210 00 60	9.97
3	MUS3 POLY BLADE, 150mm	8	81 250 00 02	1.04
4	MUS2,3 & 4 END STOP	2	81 240 00 07	0.56

<p>REVISIONS</p> <table border="1"> <thead> <tr> <th>REV.</th> <th>DESCRIPTION</th> <th>BY</th> <th>APR'VD</th> <th>DATE</th> </tr> </thead> <tbody> <tr> <td>A</td> <td>ISSUED FOR CONSTRUCTION</td> <td>KD</td> <td>JS</td> <td>21/11/25</td> </tr> </tbody> </table>					REV.	DESCRIPTION	BY	APR'VD	DATE	A	ISSUED FOR CONSTRUCTION	KD	JS	21/11/25	<p>MACHINING AND FABRICATION TOLERANCES UNO: (ALL DIMENSIONS IN mm)</p> <p>DIMENSIONAL TOLERANCE: PIPE STRAIGHTNESS</p> <p>XX ±1.0 &lt;1000 ±3.0</p> <p>XX ±0.5 &lt;2000 ±6.0</p> <p>XXX ±0.1 &lt;3000 ±9.0</p> <p>XXXX ±0.01</p> <p>ANGLE: X.X ±1.0° X.XX ±0.5°</p> <p>THERMAL CUTTING: ±1.0</p> <p>WELDMENTS: ±2.0</p> <p>CASTINGS: REFER TO CASTING NOTES</p> <p>MACHINING 'ROUGH' TO ISO 2768-vL</p> <p>MACHINING STD: TO ISO 2768-mK</p> <p>POLYURETHANE: ±2.0</p> <p>WELD SYMBOLS: IN ACCORDANCE TO ISO 2553</p> <p>MACHINED SURFACES UNO: TO BE <math>\sqrt{3.2}</math> WHERE INDICATED 'ROUGH' TO BE <math>\sqrt{3.2}</math> WHERE NOT INDICATED</p>		<p>MATERIAL: N/A</p> <p>FINISH: N/A</p> <p>COLOUR: N/A</p> <p>MFG'D: INTERNAL</p> <p>SCALE: DO NOT SCALE</p>		<p>DRAWN BY: KD</p> <p>CHECKED: JS 21/11/25</p> <p>APPROVED: JS 21/11/25</p> <p>CREATED: 4/11/2025</p>		<p>DESCRIPTION: MUS3-PU-BT-1200 S/S</p> <p>PART NO.: 82 201 72 06</p> <p>MASS: 38.19 KG</p>		<p>PROFILE CUT ITEMS: TO BE CUT FROM SUPPLIED DXF CAD FILE WHERE APPLICABLE. ADDITIONAL DIMENSIONS CAN BE PROVIDED ON REQUEST. DO NOT SCALE IF IN DOUBT.</p> <p>© COPYRIGHT. ALL RIGHTS RESERVED</p> <p>THIS DRAWING IS STRICTLY CONFIDENTIAL AND MUST NOT BE COPIED, REPRODUCED OR ADAPTED, NOR MAY ARTICLES BE MANUFACTURED IN ACCORDANCE WITH THE DRAWING WITHOUT PRIOR WRITTEN PERMISSION OF MATO AUSTRALIA PTY LTD.</p>		<p><b>mato</b></p> <p>MATO AUSTRALIA PTY LTD (INCORPORATED IN NSW) ABN 82 050 057 726</p> <p>39 BONVILLE AVE THORNTON NSW 2322 PH: 1300 850 795 FAX: (02)4936 1388</p>	
					REV.	DESCRIPTION	BY	APR'VD	DATE																	
A	ISSUED FOR CONSTRUCTION	KD	JS	21/11/25																						
<p>DRAWING NO.: 8523</p> <p>PG. SIZE: A3</p> <p>SHEET: 1 / 1</p> <p>REV: A</p>		<p>3RD ANGLE PROJECTION</p>																								

C:\Matovault\01-product\new\folder\_struct\secondary\clean\m3\bolt\_tension\82\_201\_72\_06\CAD FILES\82\_201\_72\_06