

# MDP235 CS2

MATO DROP-ON PRIMARY CLEANER

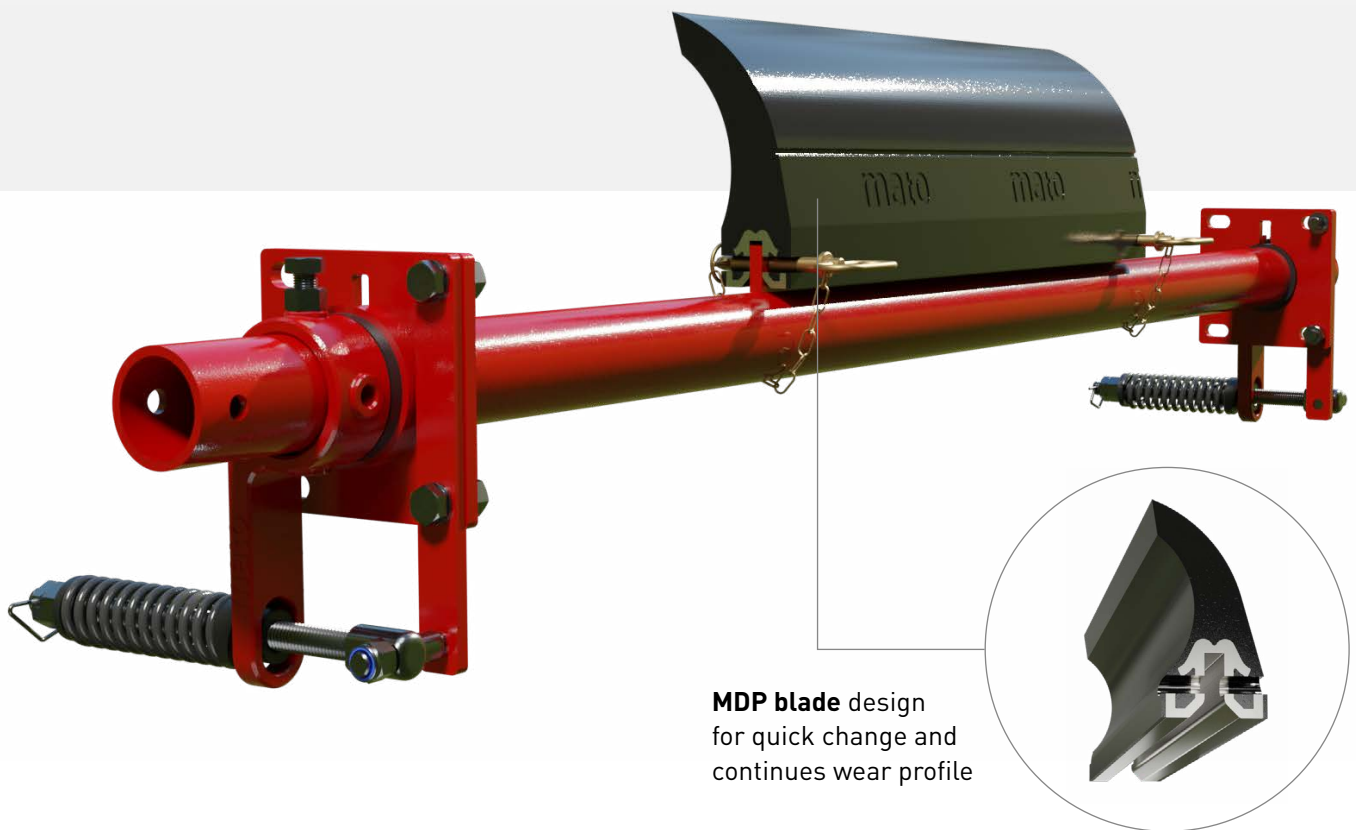

**MDP blade** design for quick change and continues wear profile

The MDP - MATO Drop-on Primary cleaner is the simplest primary cleaner available on the market, with its easy compression spring application for constant tensioning and reduce the need for adjustment.

Quick and easy blade replacement by removing the blade locking pin. The MDP range of Polyurethane Primary Cleaners are manufactured with a unique self-lubricating blade to reduce friction and blade wear.

## Features

- ✔ Reducing the amount of carry back material
- ✔ Reducing material spillage to minimize clean up work
- ✔ Reducing the potential hazard of belt mis-tracking
- ✔ Complete cleaning systems

## Benefits

- ✔ Increase conveyor belt life
- ✔ Increase production time due to excessive spillage
- ✔ Protection against wearing components on the conveyor line
- ✔ Works with MATO and other brand mechanical fasteners

# MDP235 CS2 - Technical data

## Specifications

- Blade Height 235mm
- Available in minus 150mm (6") & minus 300mm (12") blade widths
- MDP235 cleaners are supplied with a dual tensioned end assembly
- Belt speed up to 5.0m/s
- Suits pulley diameter 400mm - 1000mm
- Suitable for reversing conveyors
- Blade material 93A Shore
- Temperature rated -35°C to 82°C
- Suitable for conveyor belts with mechanical fasteners

Belt width		Shaft length		Blade width Belt width minus 150mm (6")		Blade width Belt width minus 300mm (12")		A		B		C		Weight
mm	in.	mm	in.	mm	in.	mm	in.	mm	in.	mm	in.	mm	in.	Kg
600	24	1810	71	450	18	-	-	76.1	3.0	273	10.7	311	12.2	33.2
750	30	1960	77	600	24	450	18	76.1	3.0	273	10.7	311	12.2	35.0
800	32	2015	79	650	26	500	20	76.1	3.0	273	10.7	311	12.2	40.0
900	36	2115	83	750	30	600	24	76.1	3.0	273	10.7	311	12.2	43.0
1000	40	2215	87	850	33	700	28	76.1	3.0	273	10.7	311	12.2	45.0
1050	42	2265	89	900	36	750	30	76.1	3.0	273	10.7	311	12.2	47.0
1200	48	2420	95	1050	42	900	36	76.1	3.0	273	10.7	311	12.2	51.0
1400	54	2570	101	1250	48	1100	44	76.1	3.0	273	10.7	311	12.2	55.0
1500	60	2725	107	1350	54	1200	48	76.1	3.0	273	10.7	311	12.2	60.0
1600	64	2825	111	1450	56	1300	52	76.1	3.0	273	10.7	311	12.2	62.0
1800	72	3030	119	1650	66	1500	60	76.1	3.0	273	10.7	311	12.2	68.0
2000	80	3325	131	1850	73	1700	68	76.1	3.0	273	10.7	311	12.2	73.0
2100	84	3640	143	1950	78	1800	72	76.1	3.0	273	10.7	311	12.2	76.0
2400	96	3730	147	2250	90	2100	84	76.1	3.0	273	10.7	311	12.2	85.0

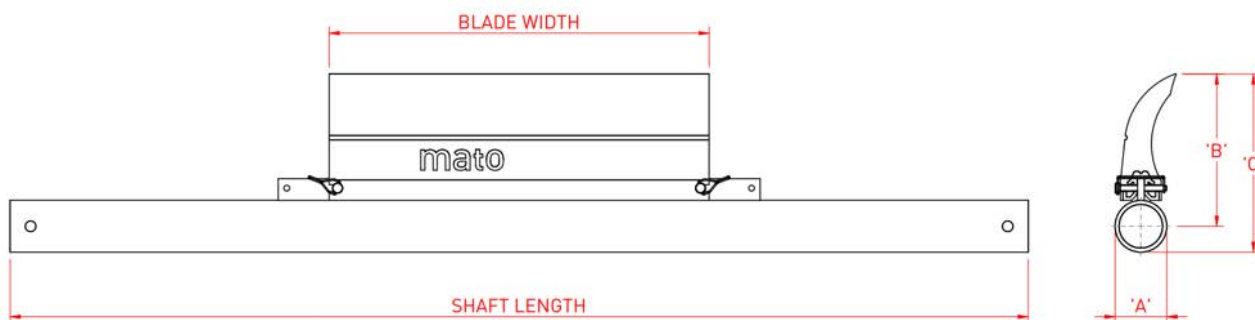

## Ordering

### MDP235 CS2, belt width minus 150mm (6")

Belt width	Blade length	Description	Part number
mm	in.	mm	in.
600	24	450 18	MDP235-P2-CS2-600/150 81 161 32 03
750	30	600 24	MDP235-P2-CS2-750/150 81 161 32 04
800	32	650 26	MDP235-P2-CS2-800/150 81 161 32 05
900	36	750 30	MDP235-P2-CS2-900/150 81 161 32 06
1000	40	850 33	MDP235-P2-CS2-1000/150 81 161 32 07
1050	42	900 36	MDP235-P2-CS2-1050/150 81 161 32 08
1200	48	1050 42	MDP235-P2-CS2-2350/150 81 161 32 09
1400	54	1250 48	MDP235-P2-CS2-1400/150 81 161 32 10
1500	60	1350 54	MDP235-P2-CS2-1500/150 81 161 32 11
1600	64	1450 56	MDP235-P2-CS2-1600/150 81 161 32 12
1800	72	1650 66	MDP235-P2-CS2-1800/150 81 161 32 13
2000	78	1850 73	MDP235-P2-CS2-2000/150 81 161 32 14
2100	82	1950 78	MDP235-P2-CS2-2100/150 81 161 32 15
2400	94	2250 90	MDP235-P2-CS2-2400/150 81 161 32 17

### MDP235 CS2, belt width minus 300mm (12")

Belt width	Blade length	Description	Part number
mm	in.	mm	in.
-	-	-	-
750	30	450 18	MDP235-P2-CS2-750/300 81 161 32 33
800	32	500 20	MDP235-P2-CS2-800/300 81 161 32 34
900	36	600 24	MDP235-P2-CS2-900/300 81 161 32 35
1000	40	700 28	MDP235-P2-CS2-1000/300 81 161 32 36
1050	42	750 30	MDP235-P2-CS2-1050/300 81 161 32 37
1200	48	900 36	MDP235-P2-CS2-1200/300 81 161 32 38
1400	54	1100 44	MDP235-P2-CS2-1400/300 81 161 32 39
1500	60	1200 48	MDP235-P2-CS2-1500/300 81 161 32 40
1600	64	1300 52	MDP235-P2-CS2-1600/300 81 161 32 41
1800	72	1500 60	MDP235-P2-CS2-1800/300 81 161 32 42
2000	80	1700 68	MDP235-P2-CS2-2000/300 81 161 32 43
2100	84	1800 72	MDP235-P2-CS2-2100/300 81 161 34 44
2400	96	2100 84	MDP235-P2-CS2-2400/300 81 161 32 45