

- ASSEMBLY NOTES:
1. UNLESS DRAWINGS ARE MARKED "FOR CONSTRUCTION", THEY SHALL NOT BE USED FOR CONSTRUCTION PURPOSES
 2. DO NOT OBTAIN DIMENSIONS BY SCALING FROM DRAWING
 3. REMOVE ALL BURRS AND SHARP EDGES
 4. ALL CUTS TO BE A MINIMUM OF CLASS 2 $\sqrt{3.2}$ FINISH UNO

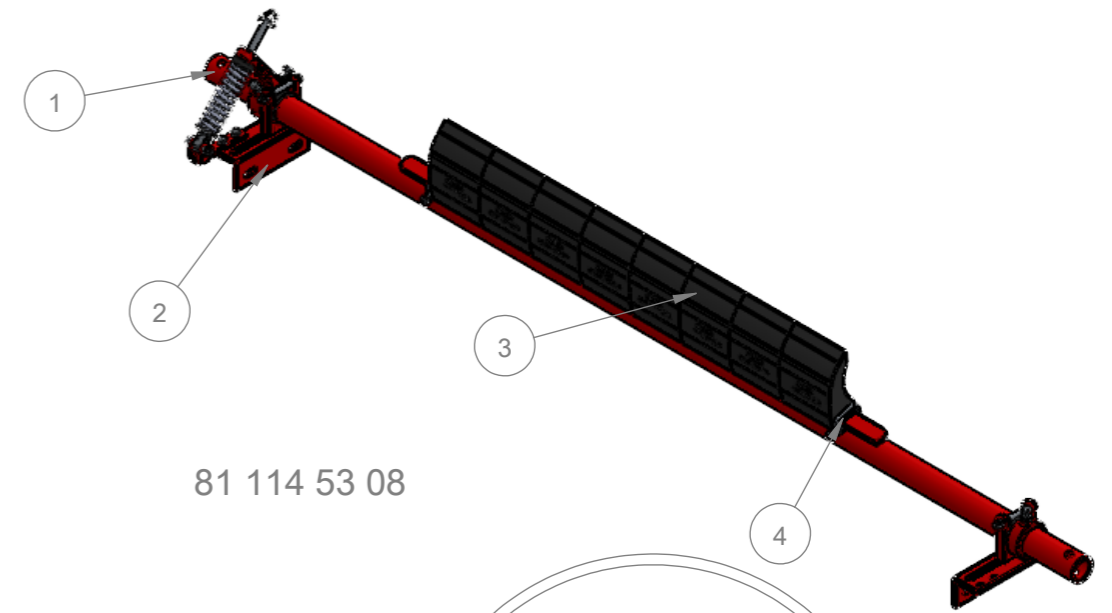

81 114 53 08

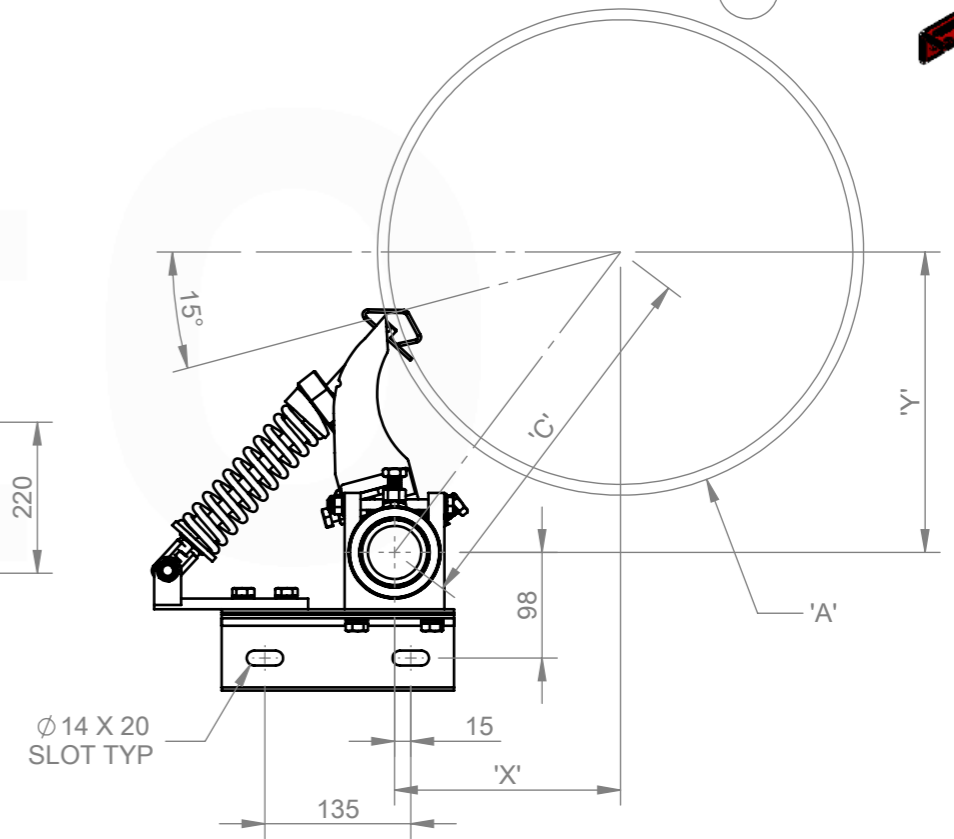
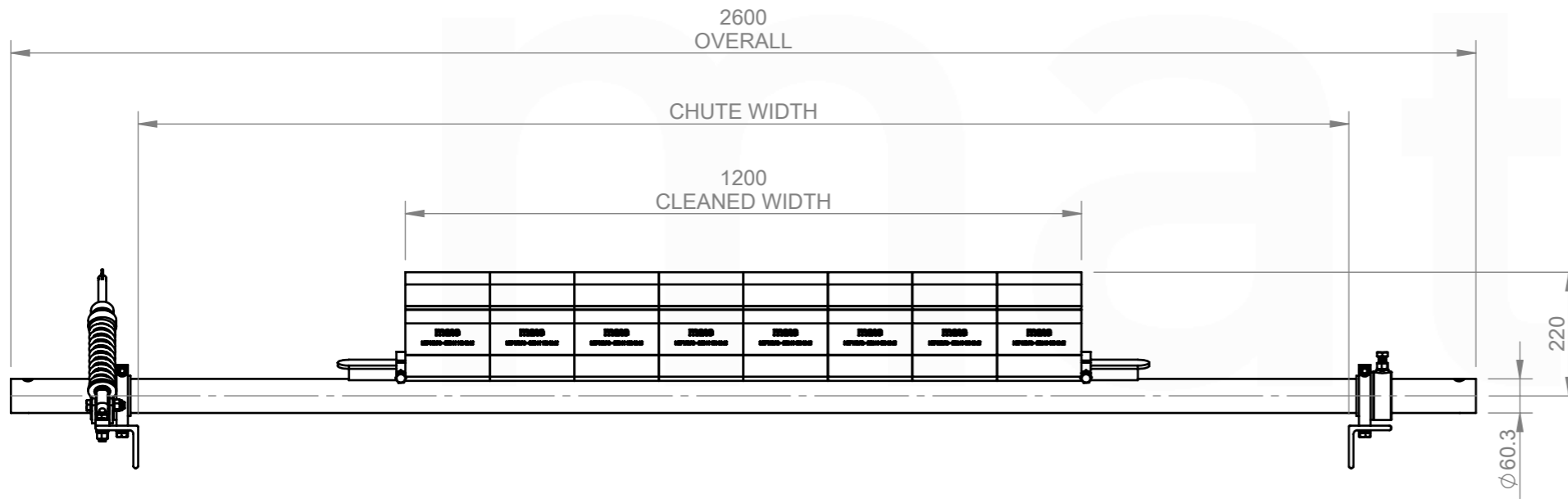

CHUTE CUT OUT DETAIL:
REFER TO CUT OUT TEMPLATE
MTP185 CS1 INSTALLATION TEMPLATE

ITEM NO.	DESCRIPTION	QTY.	PART No.	MASS k/g
1	MTP-60-1400	1	81 022 07	24.70
2	MDP 60.3 CS1 COMPRESSION SPRING END ASSEMBLY COMPLETE (SILVER SPRING)	1	81 144 00 62	9.33
3	MTP185 - P2	8	81 110 00 21	1.46
4	END STOP, ASSY. - MTP	2	82 200 00 25	0.20

REV.	DESCRIPTION	BY	APRVD	DATE
A	ISSUED FOR CONSTRUCTION	KD	JS	14/11/25
B	UPDATED DIMENSIONS	JS	DG	29/01/2026

MATERIAL: N/A	DRAWN BY JS	DESCRIPTION: MTP185-P2-CS1-1400	PROFILE CUT ITEMS: TO BE CUT FROM SUPPLIED DXF CAD FILE WHERE APPLICABLE ADDITIONAL DIMENSIONS CAN BE PROVIDED ON REQUEST. DO NOT SCALE IF IN DOUBT © COPYRIGHT, ALL RIGHTS RESERVED	mato MATO AUSTRALIA PTY LTD (INCORPORATED IN NSW) ABN 82 050 057 728 39 BONVILLE AVE THORNTON NSW 2322 PH: 1300 850 795 FAX: (02)4936 1388
FINISH: N/A	CHECKED JS 17/11/25			
COLOUR: N/A	APPROVED JS 17/11/25			
MFG'D: INTERNAL	CREATED 12/11/2025			
SCALE DO NOT SCALE	MASS: 46.13 KG	3RD ANGLE PROJECTION	DRAWING NO. 8411	PG. SIZE A3
				SHEET 1 / 1
				REV B

C:\Manufacturing\Production\NEW FOLDER STRUCTURE\PRIMARY CLEANERS\MTP - PRIMARY CLEANERS\CS1 - END ASSEMBLIES\MTP185\81 114 53 08\CAD FILES\81 114 53 08