

- ASSEMBLY NOTES:
1. UNLESS DRAWINGS ARE MARKED "FOR CONSTRUCTION", THEY SHALL NOT BE USED FOR CONSTRUCTION PURPOSES
  2. DO NOT OBTAIN DIMENSIONS BY SCALING FROM DRAWING
  3. REMOVE ALL BURRS AND SHARP EDGES
  4. ALL CUTS TO BE A MINIMUM OF CLASS 2  $\sqrt{3.2}$  FINISH UNO

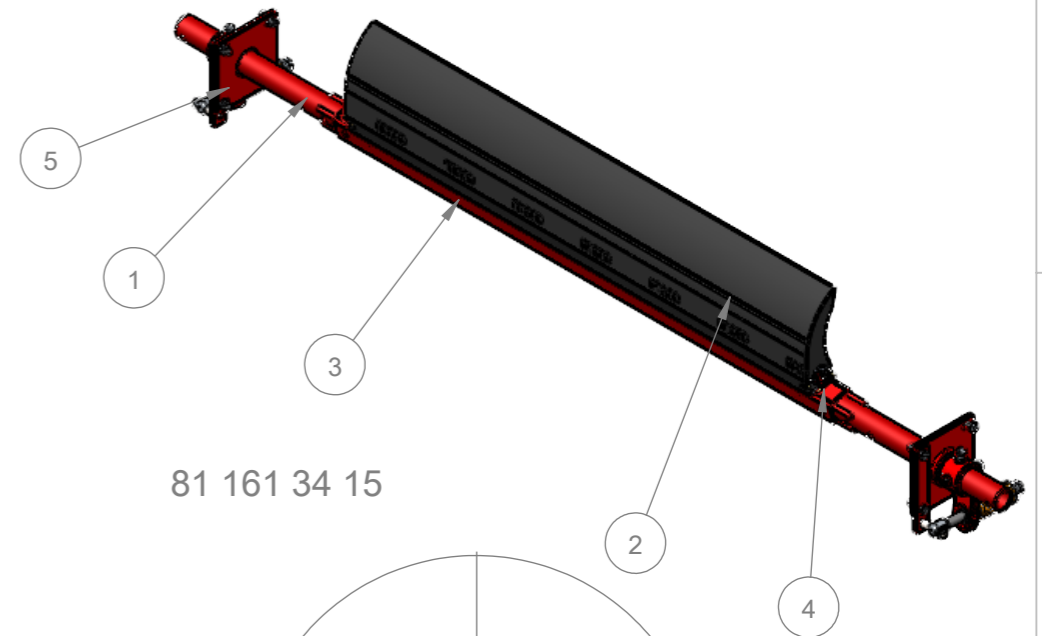

81 161 34 15

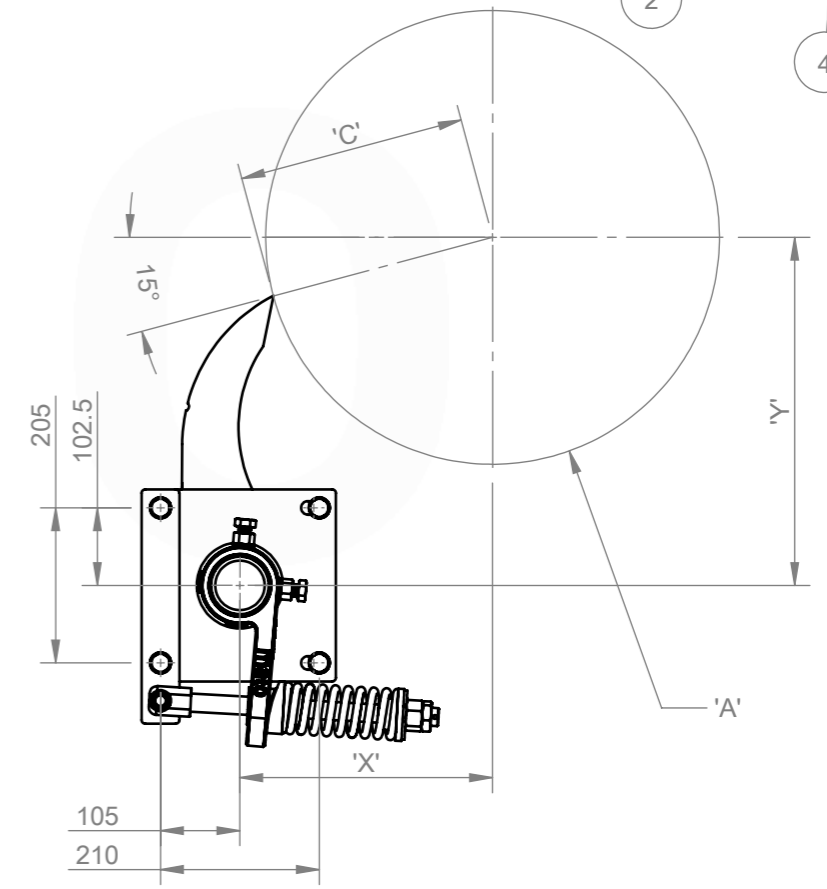
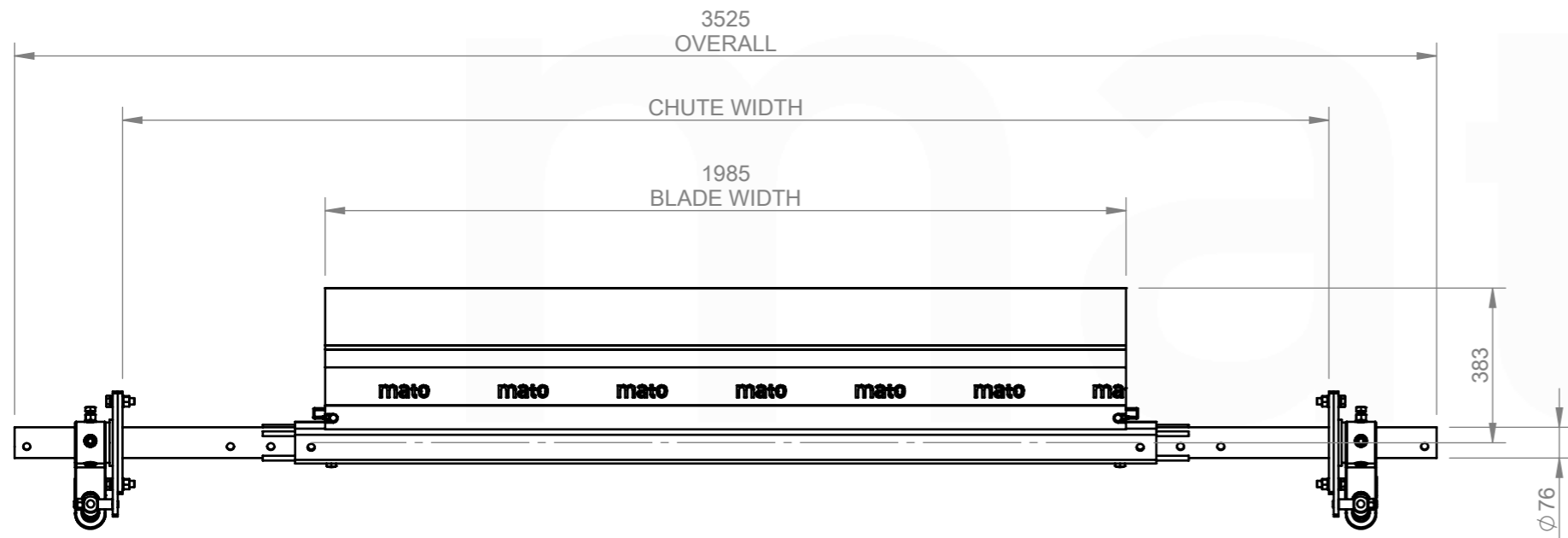

ITEM NO.	DESCRIPTION	QTY.	PART NO.	MASS K/G
1	MDP235HD/306 SHAFT EXTENSION	2	81 014 00	9.96
2	MDP306HD-P2-1950	1	81 140 34 28	62.50
3	MDPHD CENTRE SHAFT 2100	1	81 015 32	46.54
4	MDP306 BLADE RETAINING PIN	2	81 314 25	0.08
5	76.1 HD DUAL PRIMARY COMPRESSION SPRING CS2 (YELLOW) END ASSEMBLY	1	81 161 00 85	31.93

CHUTE CUT OUT DETAIL:  
REFER TO CUT OUT TEMPLATE  
MDP306 CS2 INSTALLATION TEMPLATE

REV.	DESCRIPTION	BY	APR'VD	DATE
A	ISSUED FOR CONSTRUCTION	JS	DG	19/05/2025

MATERIAL: N/A	DRAWN BY JS	DESCRIPTION: <b>MDP306HD-P2-CS2-2100/150</b>	PROFILE CUT ITEMS: TO BE CUT FROM SUPPLIED DXF CAD FILE WHERE APPLICABLE ADDITIONAL DIMENSIONS CAN BE PROVIDED ON REQUEST. DO NOT SCALE IF IN DOUBT  © COPYRIGHT, ALL RIGHTS RESERVED	<b>mato</b>  MATO AUSTRALIA PTY LTD (INCORPORATED IN NSW) ABN 82 050 057 726  39 BONVILLE AVE THORNTON NSW 2322 PH: 1300 850 795 FAX: (02)4936 1388
FINISH: N/A	CHECKED DG 09/05/25			
COLOUR: N/A	APPROVED DG 09/05/25	PART NO. <b>81 161 34 15</b>	THIS DRAWING IS STRICTLY CONFIDENTIAL AND MUST NOT BE COPIED, REPRODUCED OR ADAPTED, NOR MAY ARTICLES BE MANUFACTURED IN ACCORDANCE WITH THE DRAWING WITHOUT PRIOR WRITTEN PERMISSION OF MATO AUSTRALIA PTY LTD.	PG. SIZE A3
MFG'D: INTERNAL	CREATED 9/04/2025	MASS: 161.05 KG		
SCALE DO NOT SCALE		3RD ANGLE PROJECTION	DRAWING NO. <b>7805</b>	

C:\Mato\Auto\Auto\01-Production\NEW FOLDER STRUCTURE\PRIMARY CLEANERS\MDP - PRIMARY CLEANERS\MDP306HD\811613415\CAD FILES\811613415