

- ASSEMBLY NOTES:
1. UNLESS DRAWINGS ARE MARKED "FOR CONSTRUCTION", THEY SHALL NOT BE USED FOR CONSTRUCTION PURPOSES
  2. DO NOT OBTAIN DIMENSIONS BY SCALING FROM DRAWING
  3. REMOVE ALL BURRS AND SHARP EDGES
  4. ALL CUTS TO BE A MINIMUM OF CLASS 2  $\sqrt{3.2}$  FINISH UNO

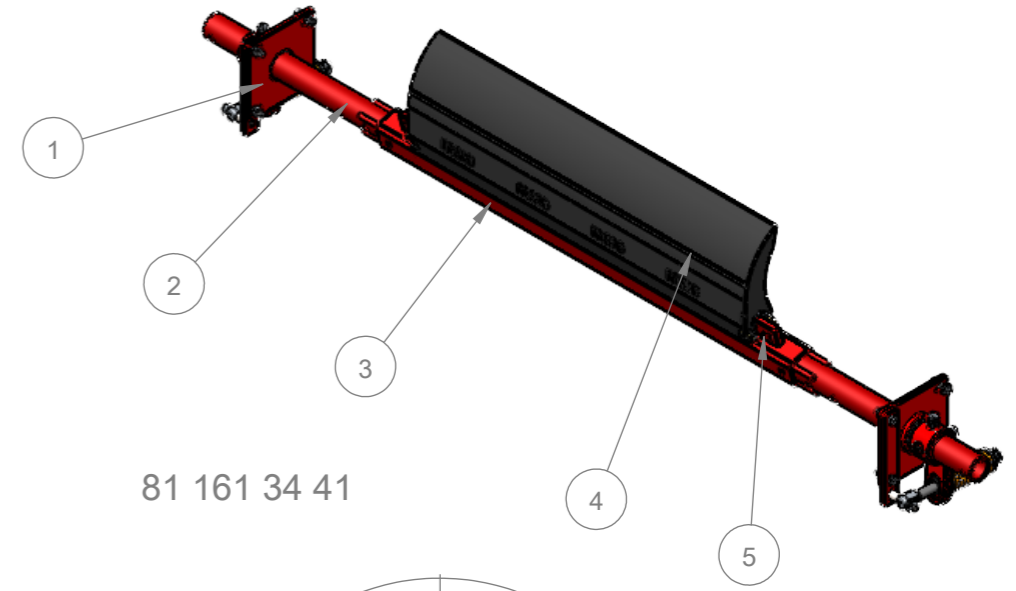

81 161 34 41

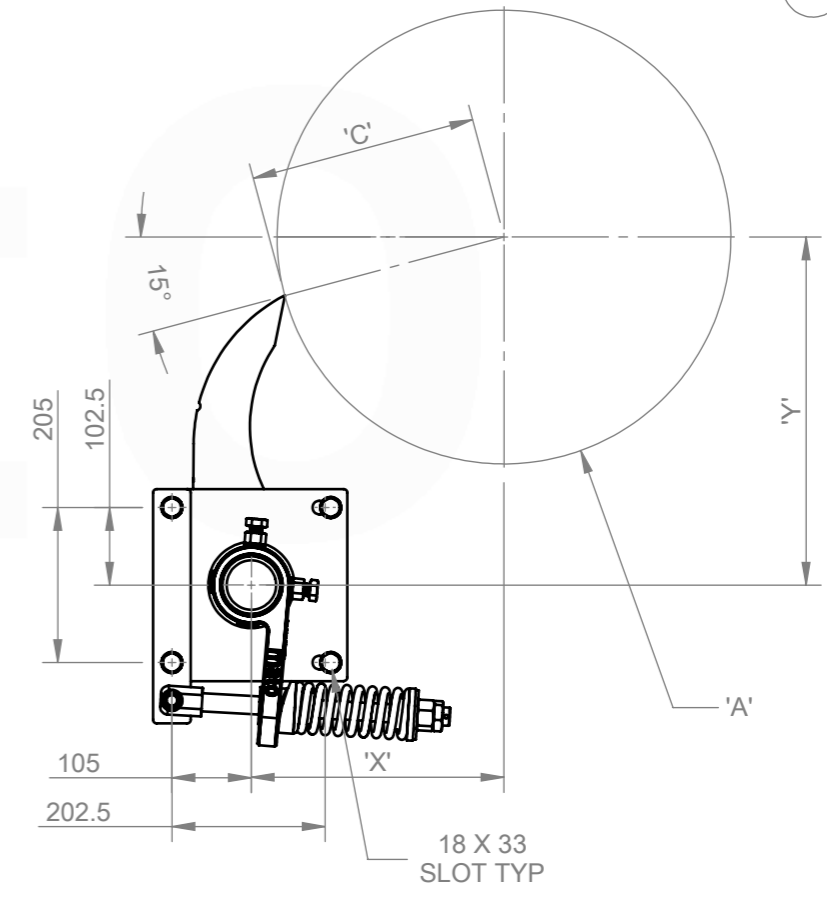
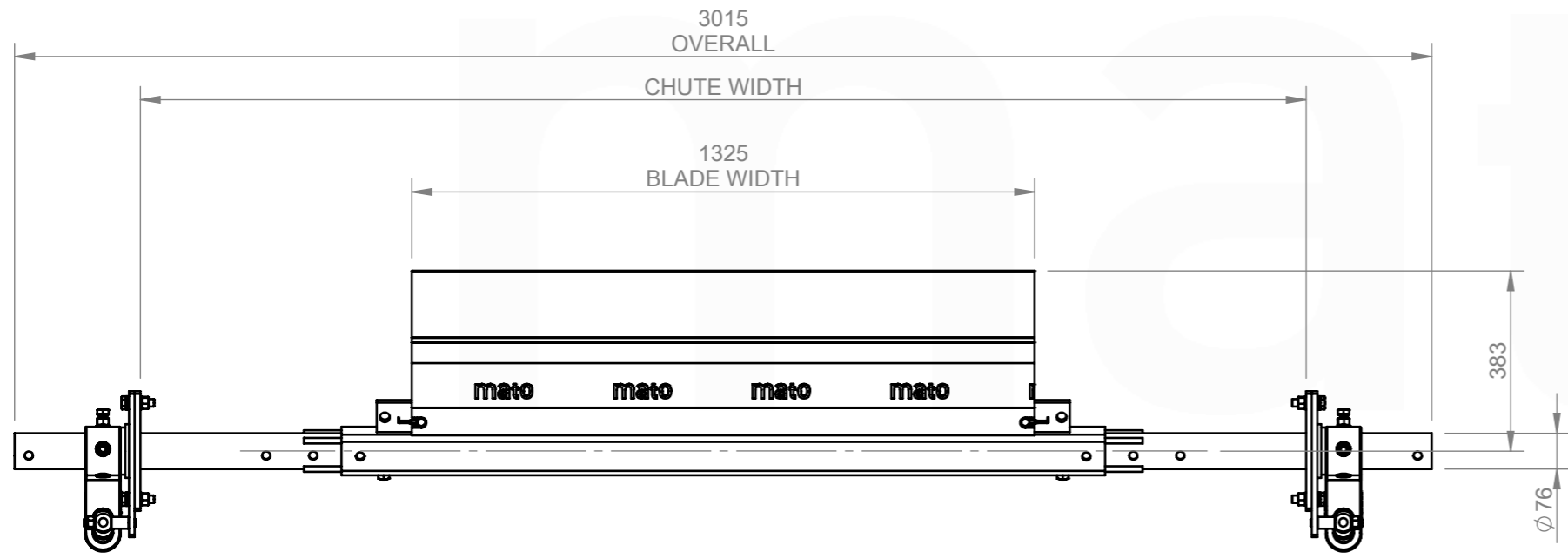

CHUTE CUT OUT DETAIL:  
REFER TO CUT OUT TEMPLATE  
MDP306 CS2 INSTALLATION TEMPLATE

ITEM NO.	DESCRIPTION	QTY.	PART No.	MASS k/g
1	76.1 HD DUAL PRIMARY COMPRESSION SPRING CS2 (YELLOW) END ASSEMBLY	1	81 161 00 85	31.93
2	MDP235HD/306 SHAFT EXTENSION	2	81 014 00	9.96
3	MDPHD Centre Shaft 1600	1	81 015 29	35.03
4	MDP306HD-P2-1300	1	81 140 34 22	41.67
5	MDP306 BLADE RETAINING PIN	2	81 314 25	0.08

REV.	DESCRIPTION	BY	APR'VD	DATE
A	ISSUED FOR CONSTRUCTION	JS	DG	19/05/2025

MATERIAL: N/A	DRAWN BY JS	DESCRIPTION: <b>MDP306HD-P2-CS2-1600/300</b>	PROFILE CUT ITEMS: TO BE CUT FROM SUPPLIED DXF CAD FILE WHERE APPLICABLE ADDITIONAL DIMENSIONS CAN BE PROVIDED ON REQUEST. DO NOT SCALE IF IN DOUBT	<b>mato</b>
FINISH: N/A	CHECKED DG 13/05/25			
COLOUR: N/A	APPROVED DG 13/05/25	PART NO. <b>81 161 34 41</b>	THIS DRAWING IS STRICTLY CONFIDENTIAL AND MUST NOT BE COPIED, REPRODUCED OR ADAPTED, NOR MAY ARTICLES BE MANUFACTURED IN ACCORDANCE WITH THE DRAWING WITHOUT PRIOR WRITTEN PERMISSION OF MATO AUSTRALIA PTY LTD.	MATO AUSTRALIA PTY LTD (INCORPORATED IN NSW) ABN 62 050 057 726 39 BONVILLE AVE THORNTON NSW 2322 PH: 1300 850 795 FAX: (02)4936 1388
MFG'D: INTERNAL	CREATED 9/04/2025	MASS: 128.70 KG		
SCALE: DO NOT SCALE	3RD ANGLE PROJECTION	PG. SIZE A3	SHEET 1 / 1	REV A

C:\Matovault\Matovault\Production\NEW FOLDER STRUCTURE\PRIMARY CLEANERS\MDP - PRIMARY CLEANERS\MDP - END ASSEMBLIES\MDP306HD\81 161 34 41\CAD FILES\81 161 34 41