

ASSEMBLY NOTES:

- UNLESS DRAWINGS ARE MARKED "FOR CONSTRUCTION", THEY SHALL NOT BE USED FOR CONSTRUCTION PURPOSES
- DO NOT OBTAIN DIMENSIONS BY SCALING FROM DRAWING
- REMOVE ALL BURRS AND SHARP EDGES
- ALL CUTS TO BE A MINIMUM OF CLASS 2 $\sqrt{3.2}$ FINISH UNO

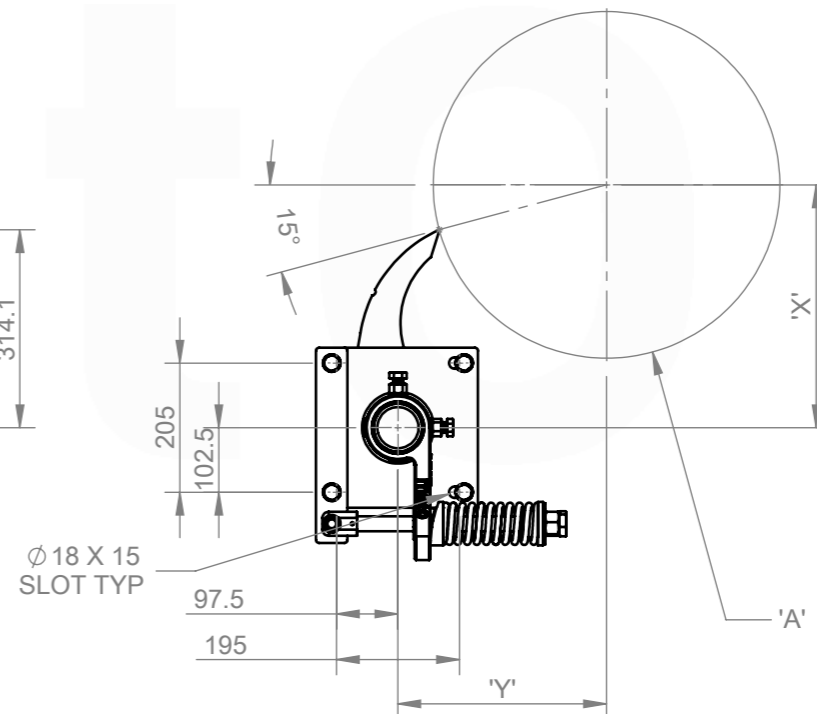
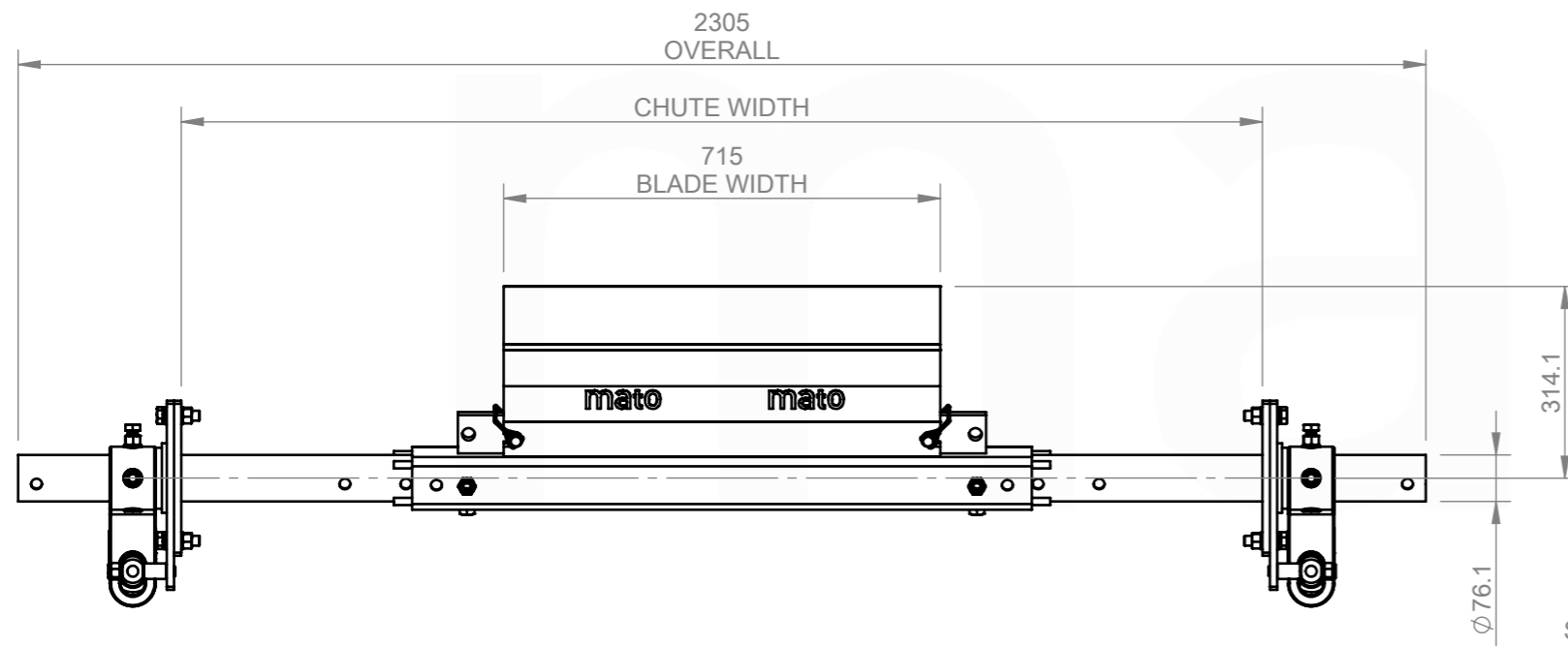
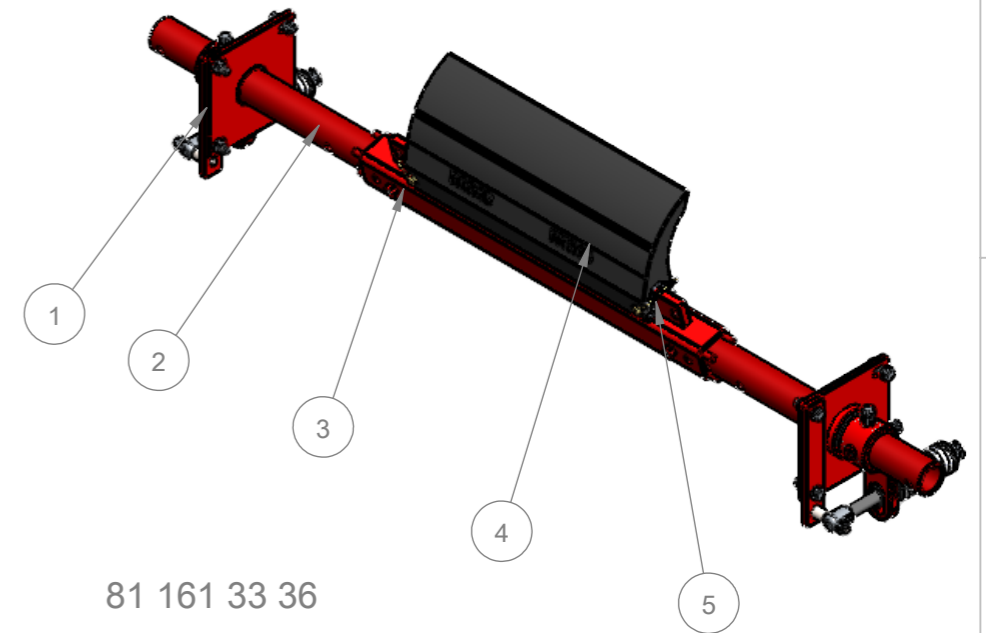

81 161 33 36

ITEM NO.	DESCRIPTION	QTY.	PART No.	MASS k/g
1	76.1 HD DUAL PRIMARY COMPRESSION SPRING CS2 (WHITE) END ASSEMBLY	1	81 161 00 83	31.72
2	MDP235HD/306 SHAFT EXTENSION	2	81 014 00	9.96
3	MDPHD Centre Shaft 1000	1	81 015 24	21.26
4	MDP235HD-P2-700	1	81 140 33 14	14.94
5	MDP235HD BLADE RETAINING PIN	2	81 314 26	0.09

CHUTE CUT OUT DETAIL:
REFER TO CUT OUT TEMPLATE
MDP235HD CS2 INSTALLATION TEMPLATE

REV.	DESCRIPTION	BY	APR'VD	DATE
A	ISSUED FOR CONSTRUCTION	JS	DG	01/09/25

MATERIAL: N/A	DRAWN BY JS	DESCRIPTION: MDP235HD-P2-CS2-1000/300	PROFILE CUT ITEMS: TO BE CUT FROM SUPPLIED DXF CAD FILE WHERE APPLICABLE ADDITIONAL DIMENSIONS CAN BE PROVIDED ON REQUEST. DO NOT SCALE IF IN DOUBT © COPYRIGHT, ALL RIGHTS RESERVED	mato MATO AUSTRALIA PTY LTD (INCORPORATED IN NSW) ABN 82 050 057 726 39 BONVILLE AVE THORNTON NSW 2322 PH: 1300 850 795 FAX: (02)4936 1388
FINISH: N/A	CHECKED DG 01/09/25			
COLOUR: N/A	APPROVED DG 01/09/25	PART NO. 81 161 33 36	THIS DRAWING IS STRICTLY CONFIDENTIAL AND MUST NOT BE COPIED, REPRODUCED OR ADAPTED, NOR MAY ARTICLES BE MANUFACTURED IN ACCORDANCE WITH THE DRAWING WITHOUT PRIOR WRITTEN PERMISSION OF MATO AUSTRALIA PTY LTD.	PG. SIZE A3
MFG'D: INTERNAL	CREATED 31/07/2025	MASS: 88.01 KG		
SCALE DO NOT SCALE		3RD ANGLE PROJECTION	DRAWING NO. 8072	

C:\Mato\Auto\Info\Production\NEW FOLDER STRUCTURE\PRIMARY CLEANERS\MDP - PRIMARY CLEANERS\CS2 - END ASSEMBLIES\MDP235HD\161 33 36\CAD FILES\161 33 36