

- ASSEMBLY NOTES:
1. UNLESS DRAWINGS ARE MARKED "FOR CONSTRUCTION", THEY SHALL NOT BE USED FOR CONSTRUCTION PURPOSES
  2. DO NOT OBTAIN DIMENSIONS BY SCALING FROM DRAWING
  3. REMOVE ALL BURRS AND SHARP EDGES
  4. ALL CUTS TO BE A MINIMUM OF CLASS 2  $\sqrt{3.2}$  FINISH UNO

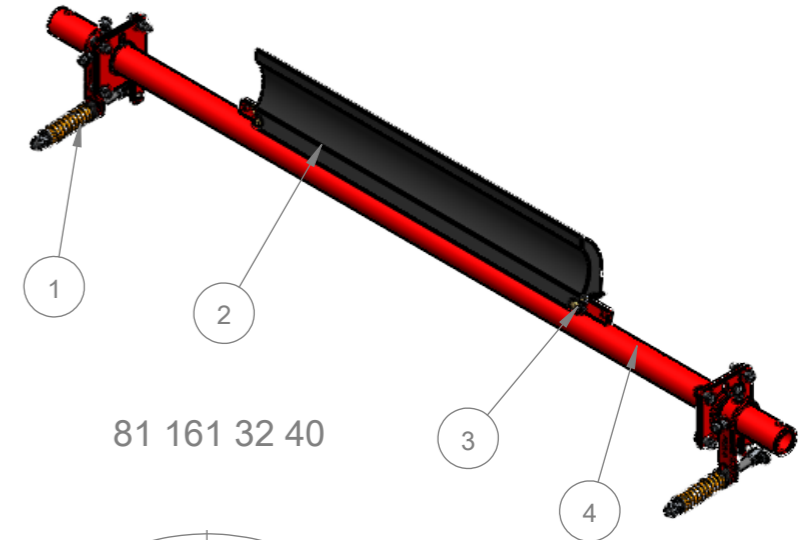

81 161 32 40

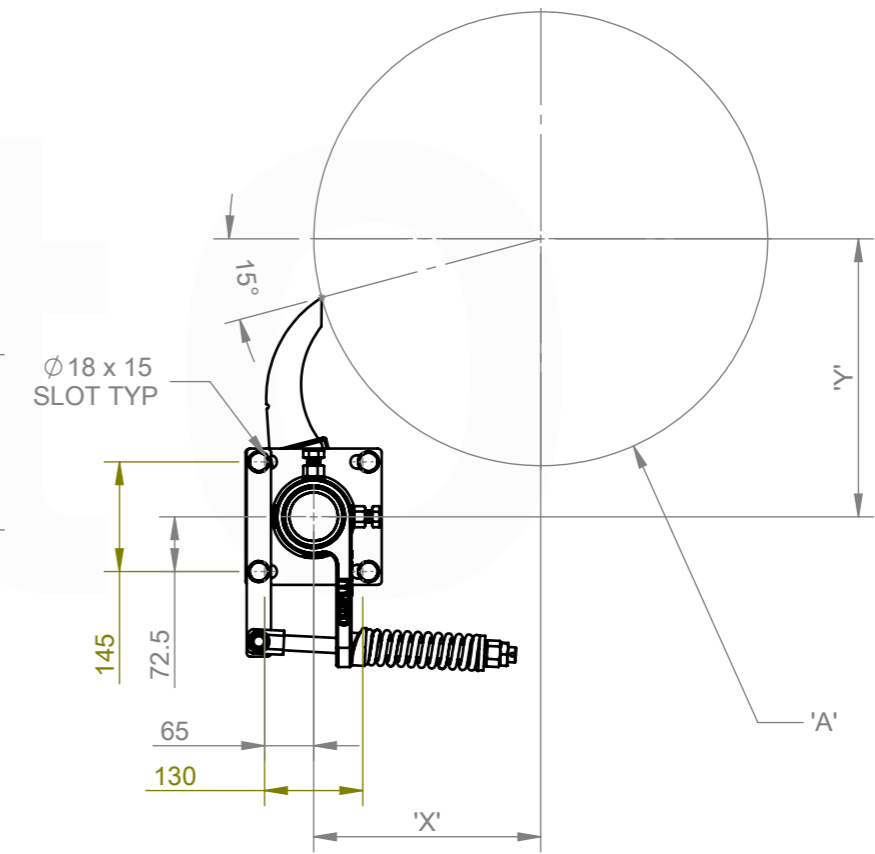
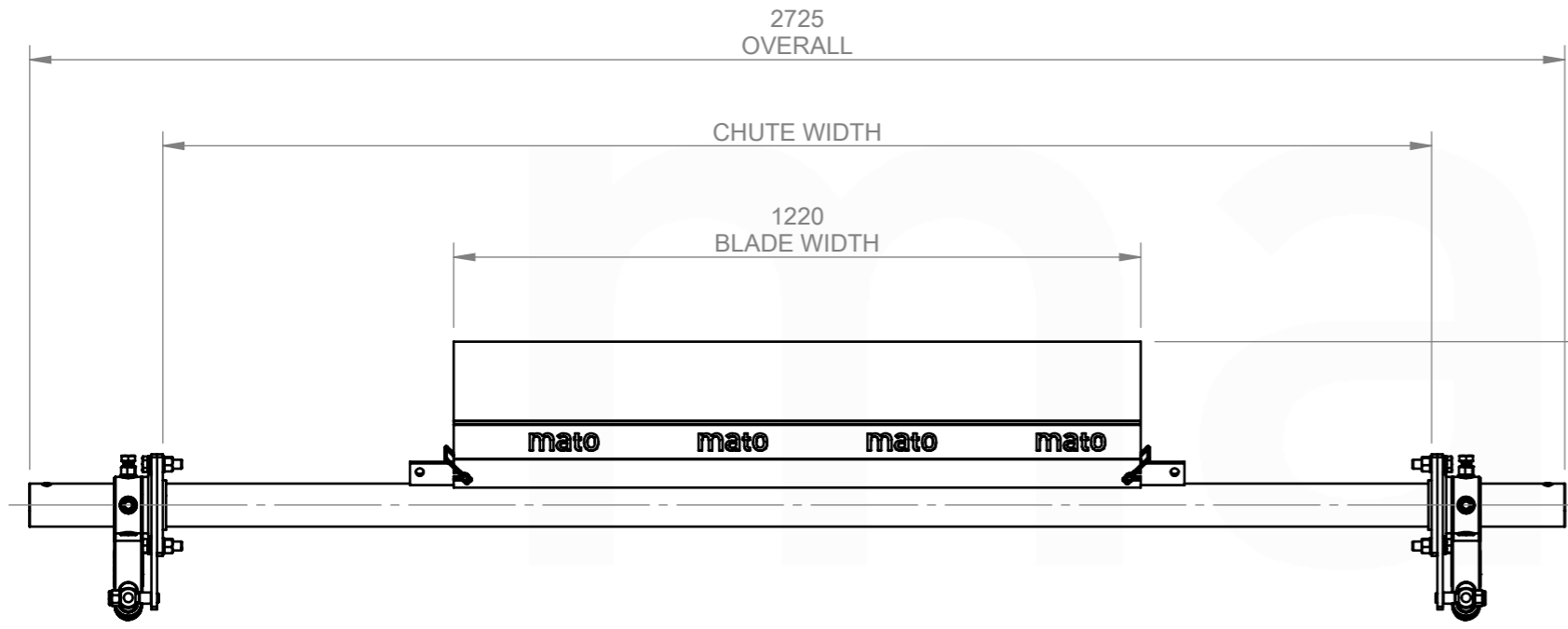

CHUTE CUT OUT DETAIL:  
REFER TO CUT OUT TEMPLATE  
MDP235 CS2 INSTALLATION TEMPLATE

ITEM NO.	DESCRIPTION	QTY.	PART No.	MASS k/g
1	76.1 MD DUAL PRIMARY COMPRESSION SPRING CS2 (YELLOW) END ASSEMBLY	1	81 161 00 81	15.47
2	MDP235-P2-1200	1	81 140 32 20	19.53
3	MDP235 BLADE RETAINING PIN	2	81 314 23	0.08
4	MDP235-76-1500	1	81 014 28	34.16

REV.	DESCRIPTION	BY	APR'VD	DATE
A	ISSUED FOR CONSTRUCTION	JS	DG	24/06/25

MATERIAL: N/A	DRAWN BY JS	DESCRIPTION: <b>MDP235-P2-CS2-1500/300</b>	PROFILE CUT ITEMS: TO BE CUT FROM SUPPLIED DXF CAD FILE WHERE APPLICABLE ADDITIONAL DIMENSIONS CAN BE PROVIDED ON REQUEST. DO NOT SCALE IF IN DOUBT  © COPYRIGHT, ALL RIGHTS RESERVED	<b>mato</b>  MATO AUSTRALIA PTY LTD (INCORPORATED IN NSW) ABN 62 050 057 726  38 BONVILLE AVE THORNTON NSW 2322 PH: 1300 850 795 FAX: (02)4936 1388
FINISH: N/A	CHECKED DG 24/06/25			
COLOUR: N/A	APPROVED DG 24/06/25	PART NO. <b>81 161 32 40</b>	THIS DRAWING IS STRICTLY CONFIDENTIAL AND MUST NOT BE COPIED, REPRODUCED OR ADAPTED, NOR MAY ARTICLES BE MANUFACTURED IN ACCORDANCE WITH THE DRAWING WITHOUT PRIOR WRITTEN PERMISSION OF MATO AUSTRALIA PTY LTD.	PG. SIZE A3
MFG'D: INTERNAL	CREATED 6/06/2025	MASS: 69.32 KG		
SCALE DO NOT SCALE		3RD ANGLE PROJECTION	DRAWING NO. <b>7915</b>	

C:\MATO\VAULT\PRODUCTION\NEW FOLDER STRUCTURE\PRIMARY CLEANERS\MDP - PRIMARY CLEANERS\CS2 - END ASSEMBLES\MDP235\81 161 32 40\CAD FILES\81 161 32 40