

- ASSEMBLY NOTES:
1. UNLESS DRAWINGS ARE MARKED "FOR CONSTRUCTION", THEY SHALL NOT BE USED FOR CONSTRUCTION PURPOSES
 2. DO NOT OBTAIN DIMENSIONS BY SCALING FROM DRAWING
 3. REMOVE ALL BURRS AND SHARP EDGES
 4. ALL CUTS TO BE A MINIMUM OF CLASS 2 $\sqrt{3.2}$ FINISH UNO

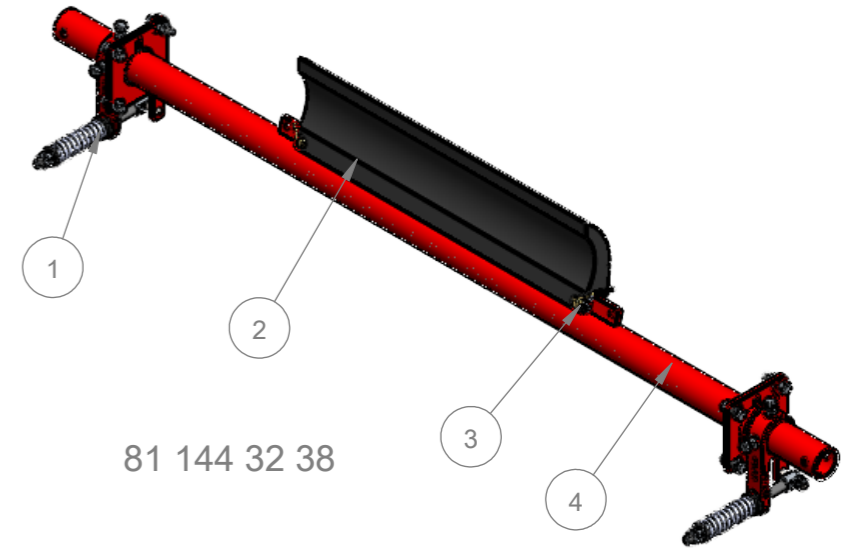

81 144 32 38

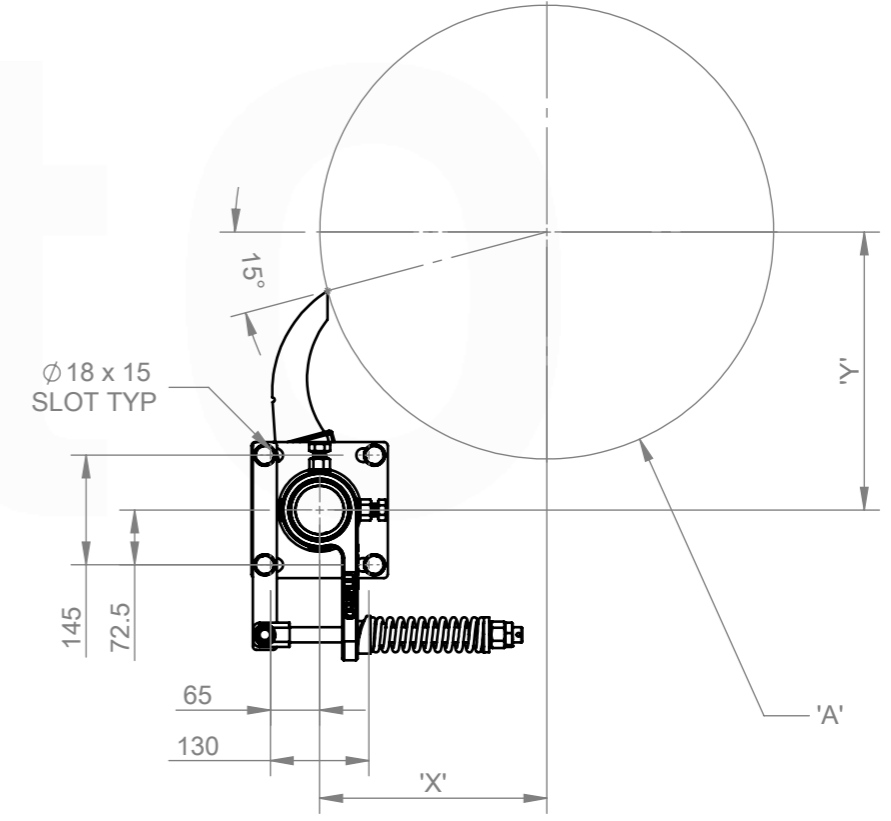
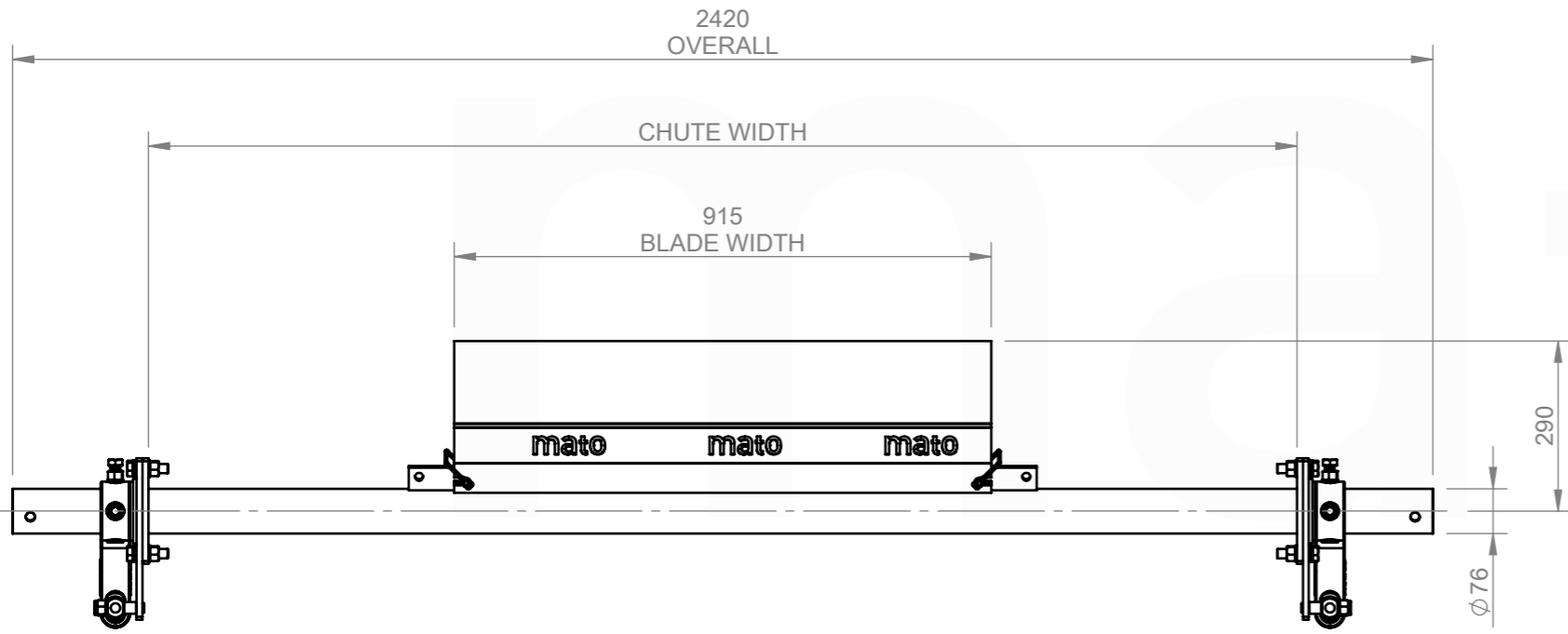

CHUTE CUT OUT DETAIL:
REFER TO CUT OUT TEMPLATE
MDP235 CS2 INSTALLATION TEMPLATE

ITEM NO.	DESCRIPTION	QTY.	PART No.	MASS k/g
1	76.1 MD DUAL PRIMARY COMPRESSION SPRING CS2 (SILVER) END ASSEMBLY	1	81 161 00 79	16.16
2	MDP235-P2-900	1	81 140 32 17	14.63
3	MDP235 BLADE RETAINING PIN	2	81 314 23	0.08
4	MDP235-76-1200	1	81 014 26	29.77

REV.	DESCRIPTION	BY	APR'VD	DATE
A	ISSUED FOR CONSTRUCTION	JS	DG	24/06/25

MATERIAL: N/A	DRAWN BY JS	DESCRIPTION: MDP235-P2-CS2-1200/300	PROFILE CUT ITEMS: TO BE CUT FROM SUPPLIED DXF CAD FILE WHERE APPLICABLE ADDITIONAL DIMENSIONS CAN BE PROVIDED ON REQUEST. DO NOT SCALE IF IN DOUBT © COPYRIGHT, ALL RIGHTS RESERVED	mato MATO AUSTRALIA PTY LTD (INCORPORATED IN NSW) ABN 62 050 057 726 39 BONVILLE AVE THORNTON NSW 2322 PH: 1300 850 795 FAX: (02)4936 1388	
FINISH: N/A	CHECKED DG 24/06/25				
COLOUR: N/A	APPROVED DG 24/06/25				
MFG'D: INTERNAL	CREATED 6/06/2025				
SCALE DO NOT SCALE	MASS: 60.72 KG	PART NO. 81 144 32 38	THIS DRAWING IS STRICTLY CONFIDENTIAL AND MUST NOT BE COPIED, REPRODUCED OR ADAPTED, NOR MAY ARTICLES BE MANUFACTURED IN ACCORDANCE WITH THE DRAWING WITHOUT PRIOR WRITTEN PERMISSION OF MATO AUSTRALIA PTY LTD.	DRAWING NO. 7913	
		3RD ANGLE PROJECTION	PG. SIZE A3	SHEET 1 / 1	REV A

C:\Mato\Auto\Auto\01-Production\NEW FOLDER STRUCTURE\PRIMARY CLEANERS\MDP - PRIMARY CLEANERS\CS2 - END ASSEMBLIES\MDP235\91 161 32 38\CAD FILES\91 161 32 38