

- ASSEMBLY NOTES:
1. UNLESS DRAWINGS ARE MARKED "FOR CONSTRUCTION", THEY SHALL NOT BE USED FOR CONSTRUCTION PURPOSES
 2. DO NOT OBTAIN DIMENSIONS BY SCALING FROM DRAWING
 3. REMOVE ALL BURRS AND SHARP EDGES
 4. ALL CUTS TO BE A MINIMUM OF CLASS 2 $\sqrt{3.2}$ FINISH UNO

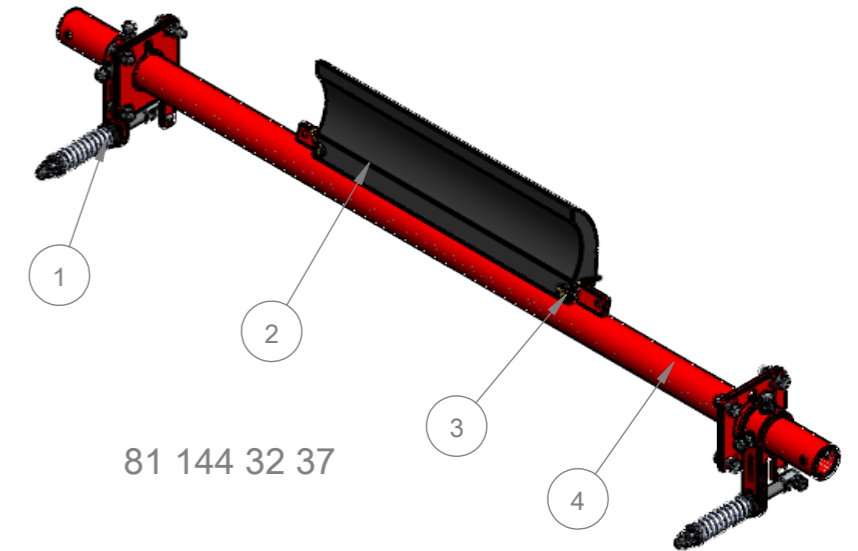

81 144 32 37

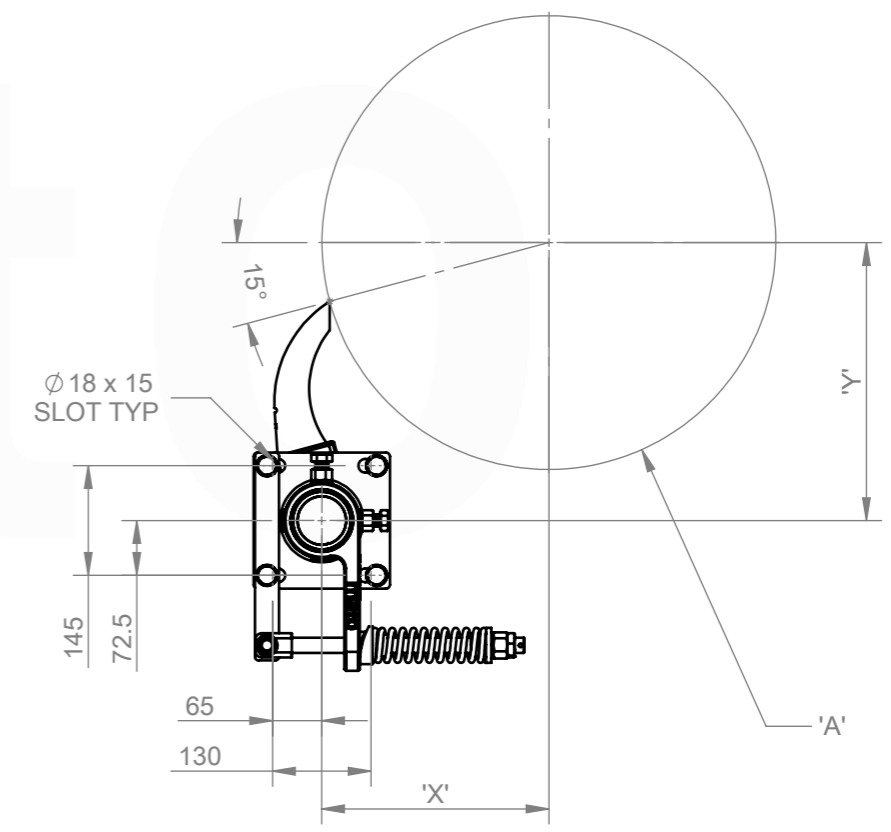
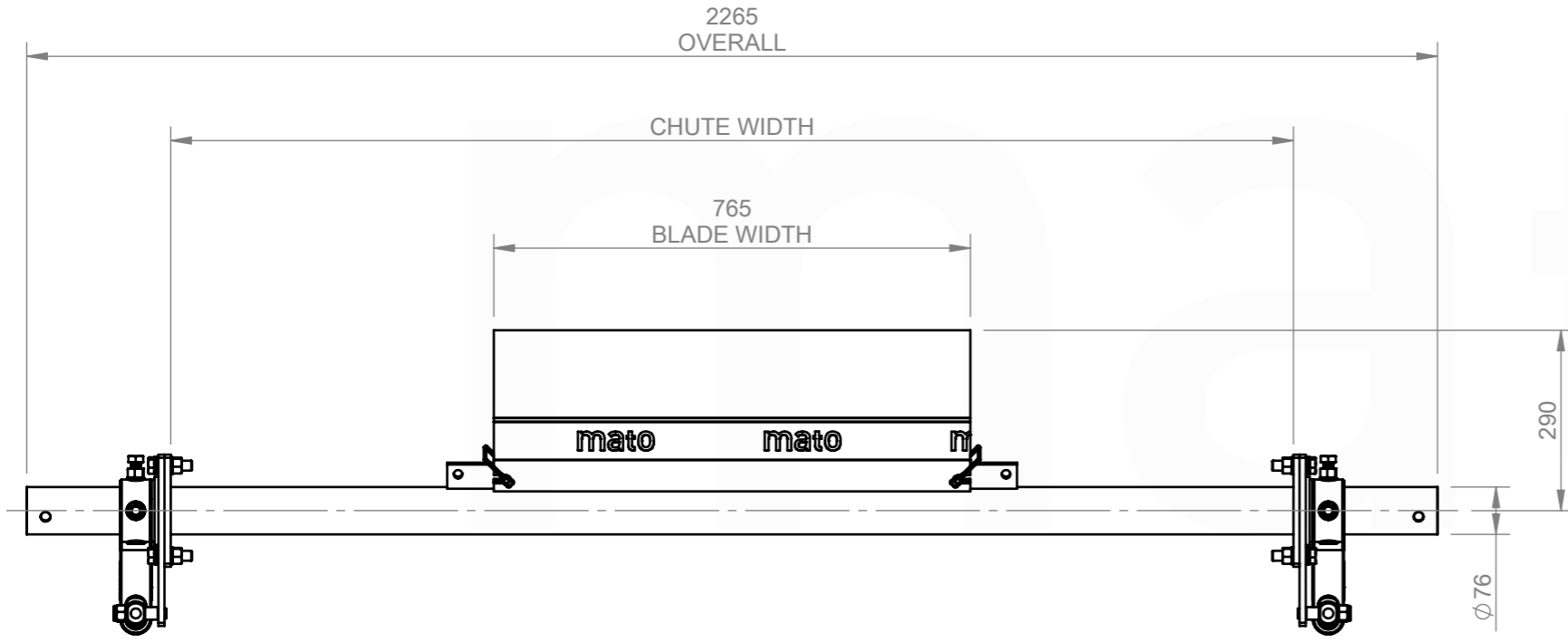

CHUTE CUT OUT DETAIL:
REFER TO CUT OUT TEMPLATE
MDP235 CS2 INSTALLATION TEMPLATE

ITEM NO.	DESCRIPTION	QTY.	PART No.	MASS k/g
1	76.1 MD DUAL PRIMARY COMPRESSION SPRING CS2 (SILVER) END ASSEMBLY	1	81 161 00 79	16.16
2	MDP235-P2-750	1	81 140 32 15	12.23
3	MDP235 BLADE RETAINING PIN	2	81 314 23	0.08
4	MDP235-76-1050	1	81 014 25	27.54

REV.	DESCRIPTION	BY	APR'VD	DATE
A	ISSUED FOR CONSTRUCTION	JS	DG	24/06/25

MATERIAL: N/A	DRAWN BY JS	DESCRIPTION: MDP235-P2-CS2-1050/300	PROFILE CUT ITEMS: TO BE CUT FROM SUPPLIED DXF CAD FILE WHERE APPLICABLE ADDITIONAL DIMENSIONS CAN BE PROVIDED ON REQUEST. DO NOT SCALE IF IN DOUBT © COPYRIGHT, ALL RIGHTS RESERVED	mato MATO AUSTRALIA PTY LTD (INCORPORATED IN NSW) ABN 62 050 057 726 39 BONVILLE AVE THORNTON NSW 2322 PH: 1300 850 795 FAX: (02)4936 1388
FINISH: N/A	CHECKED DG 24/06/25			
COLOUR: N/A	APPROVED DG 24/06/25			
MFG'D: INTERNAL	CREATED 6/06/2025			
SCALE DO NOT SCALE	MASS: 56.07 KG	3RD ANGLE PROJECTION	DRAWING NO. 7912	PG. SIZE A3
				SHEET 1 / 1
				REV A

C:\Mato\Auto\Auto\Production\NEW FOLDER STRUCTURE\PRIMARY CLEANERS\MDP - PRIMARY CLEANERS\CS2 - END ASSEMBLIES\MDP235\161.32.37\CAD FILES\91.161.32.37