

- ASSEMBLY NOTES:
1. UNLESS DRAWINGS ARE MARKED "FOR CONSTRUCTION", THEY SHALL NOT BE USED FOR CONSTRUCTION PURPOSES
 2. DO NOT OBTAIN DIMENSIONS BY SCALING FROM DRAWING
 3. REMOVE ALL BURRS AND SHARP EDGES
 4. ALL CUTS TO BE A MINIMUM OF CLASS 2 $\sqrt{3.2}$ FINISH UNO

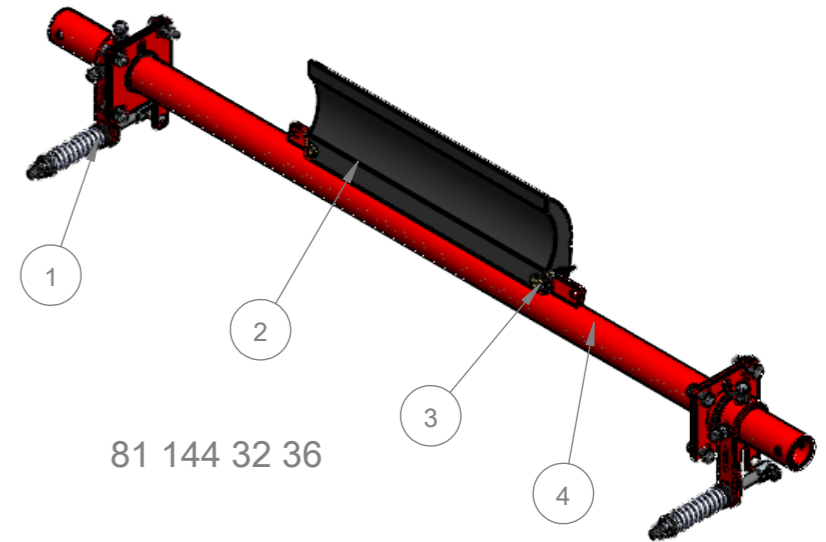

81 144 32 36

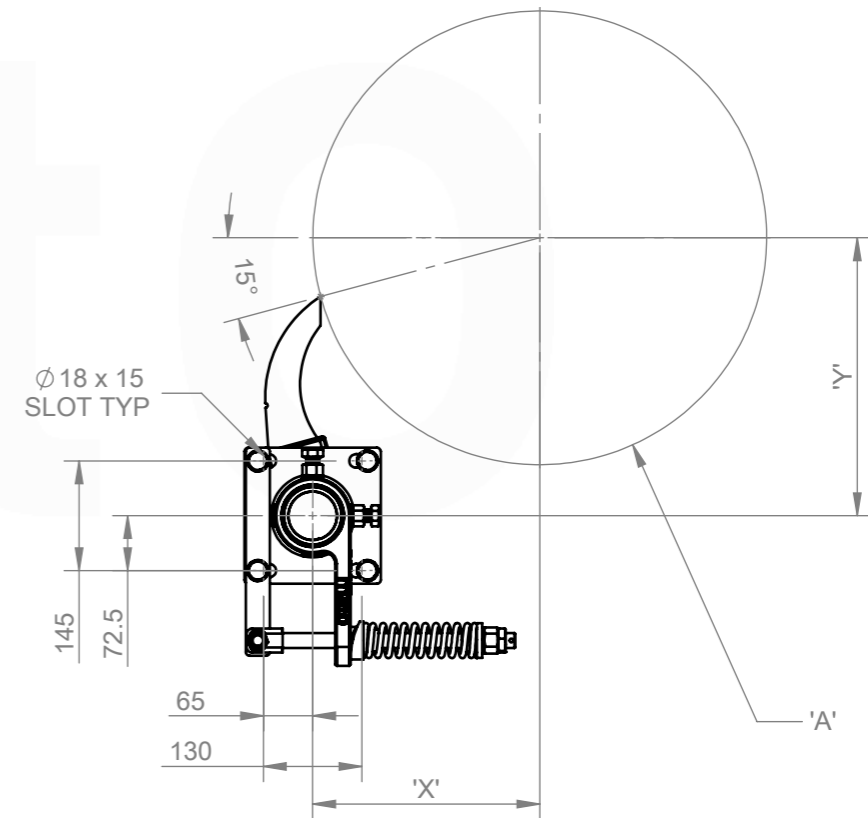
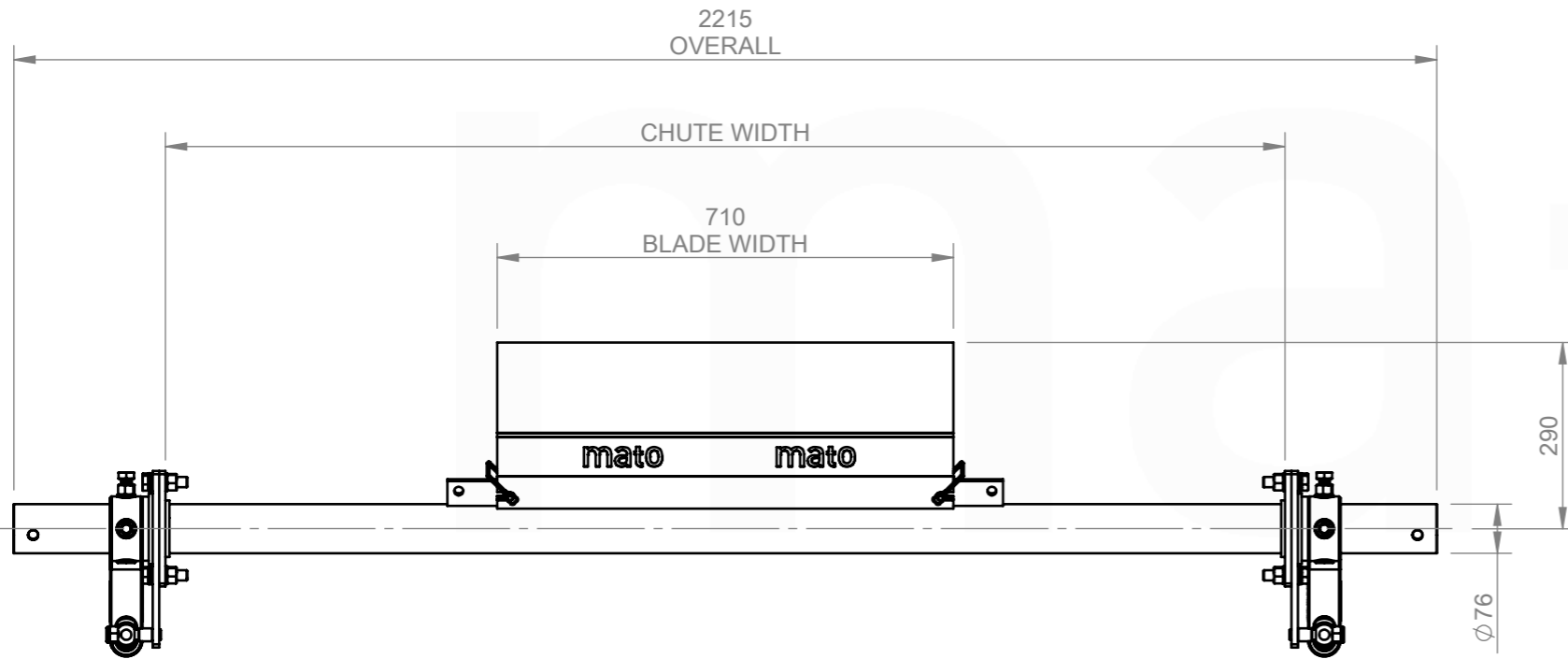

CHUTE CUT OUT DETAIL:
REFER TO CUT OUT TEMPLATE
MDP235 CS2 INSTALLATION TEMPLATE

ITEM NO.	DESCRIPTION	QTY.	PART No.	MASS k/g
1	73.0 MD DUAL PRIMARY COMPRESSION SPRING CS2 (SILVER) END ASSEMBLY	1	81 161 00 78	16.25
2	MDP235-P2-700	1	81 140 32 14	11.34
3	MDP235 BLADE RETAINING PIN	2	81 314 23	0.08
4	MDP235-76-1000	1	81 014 24	26.82

<p>REVISIONS</p> <table border="1"> <thead> <tr> <th>REV.</th> <th>DESCRIPTION</th> <th>BY</th> <th>APR'VD</th> <th>DATE</th> </tr> </thead> <tbody> <tr> <td>A</td> <td>ISSUED FOR CONSTRUCTION</td> <td>JS</td> <td>DG</td> <td>24/06/25</td> </tr> </tbody> </table>					REV.	DESCRIPTION	BY	APR'VD	DATE	A	ISSUED FOR CONSTRUCTION	JS	DG	24/06/25	<p>MACHINING AND FABRICATION TOLERANCES UNO: (ALL DIMENSIONS IN mm)</p> <p>DIMENSIONAL TOLERANCE: PIPE STRAIGHTNESS</p> <p>X.X ±1.0 <1000 ±3.0</p> <p>X.XX ±0.5 <2000 ±6.0</p> <p>X.XXX ±0.1 <3000 ±9.0</p> <p>X.XXXX ±0.01</p> <p>ANGLE: X.X ±1.0° X.XX ±0.5°</p> <p>THERMAL CUTTING: ±1.0</p> <p>WELDMENTS: ±2.0</p> <p>CASTINGS: REFER TO CASTING NOTES</p> <p>MACHINING "ROUGH" TO ISO 2768-vL</p> <p>MACHINING STD: TO ISO 2768-mK</p> <p>POLYURETHANE: ±2.0</p> <p>WELD SYMBOLS: IN ACCORDANCE TO ISO 2553</p> <p>MACHINED SURFACES UNO:</p> <p>TO BE $\sqrt{12.5}$ WHERE INDICATED "ROUGH"</p> <p>TO BE $\sqrt{3.2}$ WHERE NOT INDICATED</p>		<p>MATERIAL: N/A</p> <p>FINISH: N/A</p> <p>COLOUR: N/A</p> <p>MFG'D: INTERNAL</p> <p>SCALE: DO NOT SCALE</p>		<p>DRAWN BY: JS</p> <p>CHECKED: DG 24/06/25</p> <p>APPROVED: DG 24/06/25</p> <p>CREATED: 6/06/2025</p>		<p>DESCRIPTION: MDP235-P2-CS2-1000/300</p> <p>PART NO.: 81 144 32 36</p> <p>MASS: 54.56 KG</p>		<p>PROFILE CUT ITEMS: TO BE CUT FROM SUPPLIED DXF CAD FILE WHERE APPLICABLE. ADDITIONAL DIMENSIONS CAN BE PROVIDED ON REQUEST. DO NOT SCALE IF IN DOUBT.</p> <p>© COPYRIGHT, ALL RIGHTS RESERVED</p> <p>THIS DRAWING IS STRICTLY CONFIDENTIAL AND MUST NOT BE COPIED, REPRODUCED OR ADAPTED, NOR MAY ARTICLES BE MANUFACTURED IN ACCORDANCE WITH THE DRAWING WITHOUT PRIOR WRITTEN PERMISSION OF MATO AUSTRALIA PTY LTD.</p>		<p>mato</p> <p>MATO AUSTRALIA PTY LTD (INCORPORATED IN NSW) ABN 62 050 057 726</p> <p>39 BONVILLE AVE THORNTON NSW 2322 PH: 1300 850 795 FAX: (02)4936 1388</p>	
					REV.	DESCRIPTION	BY	APR'VD	DATE																	
A	ISSUED FOR CONSTRUCTION	JS	DG	24/06/25																						
<p>DRAWING NO.: 7911</p> <p>PG. SIZE: A3</p> <p>SHEET: 1 / 1</p> <p>REV: A</p>		<p>3RD ANGLE PROJECTION</p>		<p>MASS: 54.56 KG</p>		<p>DESCRIPTION: MDP235-P2-CS2-1000/300</p>		<p>PROFILE CUT ITEMS: TO BE CUT FROM SUPPLIED DXF CAD FILE WHERE APPLICABLE. ADDITIONAL DIMENSIONS CAN BE PROVIDED ON REQUEST. DO NOT SCALE IF IN DOUBT.</p>		<p>mato</p>																

C:\MATO\VAULT\PRODUCTION\NEW FOLDER STRUCTURE\PRIMARY CLEANERS\MDP - PRIMARY CLEANERS\CS2 - END ASSEMBLES\MDP235\81 144 32 36\CAD FILES\81 144 32 36