

- ASSEMBLY NOTES:
1. UNLESS DRAWINGS ARE MARKED "FOR CONSTRUCTION", THEY SHALL NOT BE USED FOR CONSTRUCTION PURPOSES
  2. DO NOT OBTAIN DIMENSIONS BY SCALING FROM DRAWING
  3. REMOVE ALL BURRS AND SHARP EDGES
  4. ALL CUTS TO BE A MINIMUM OF CLASS 2  $\sqrt{3.2}$  FINISH UNO

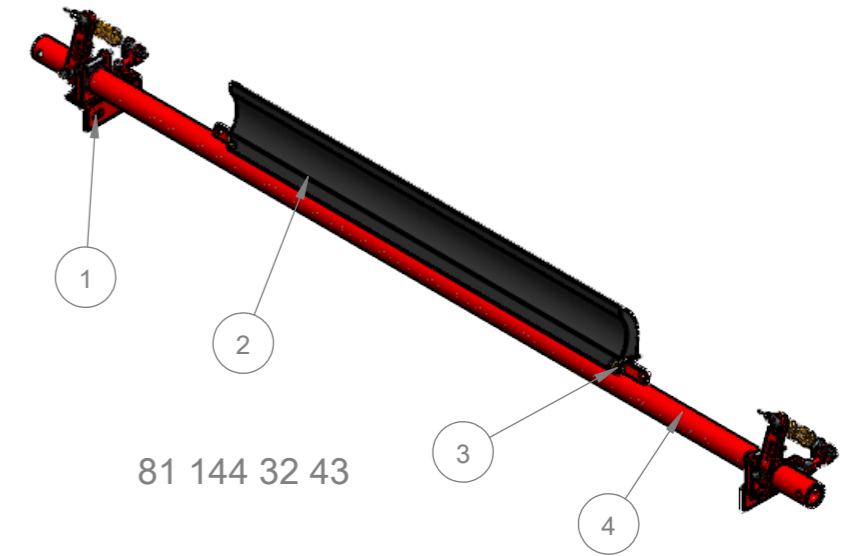

81 144 32 43

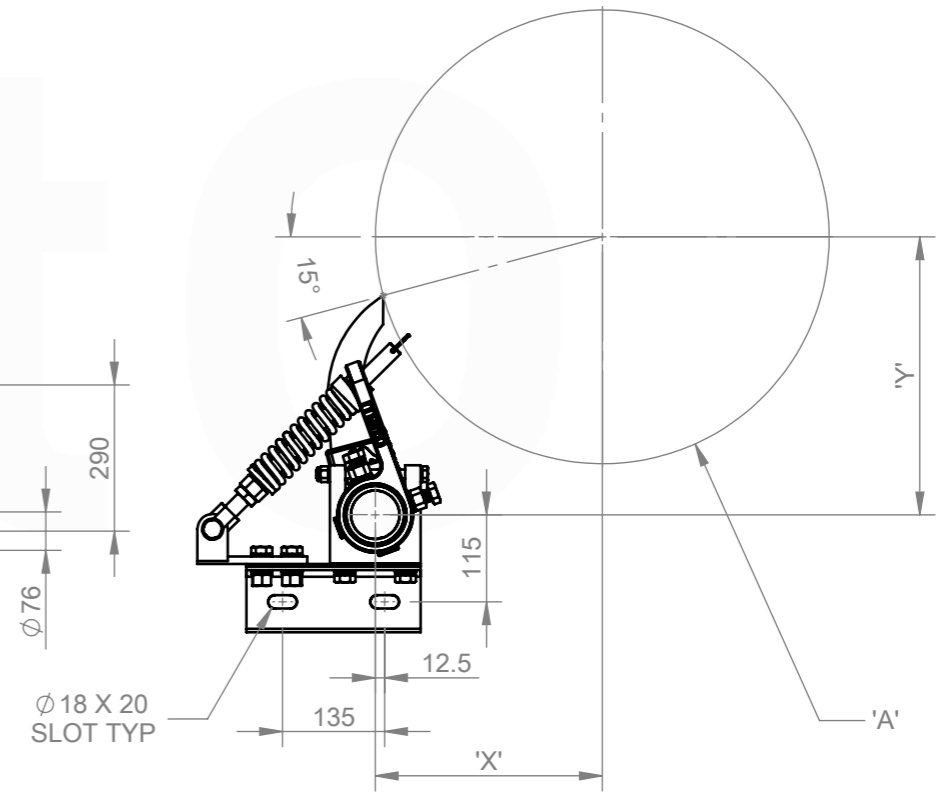
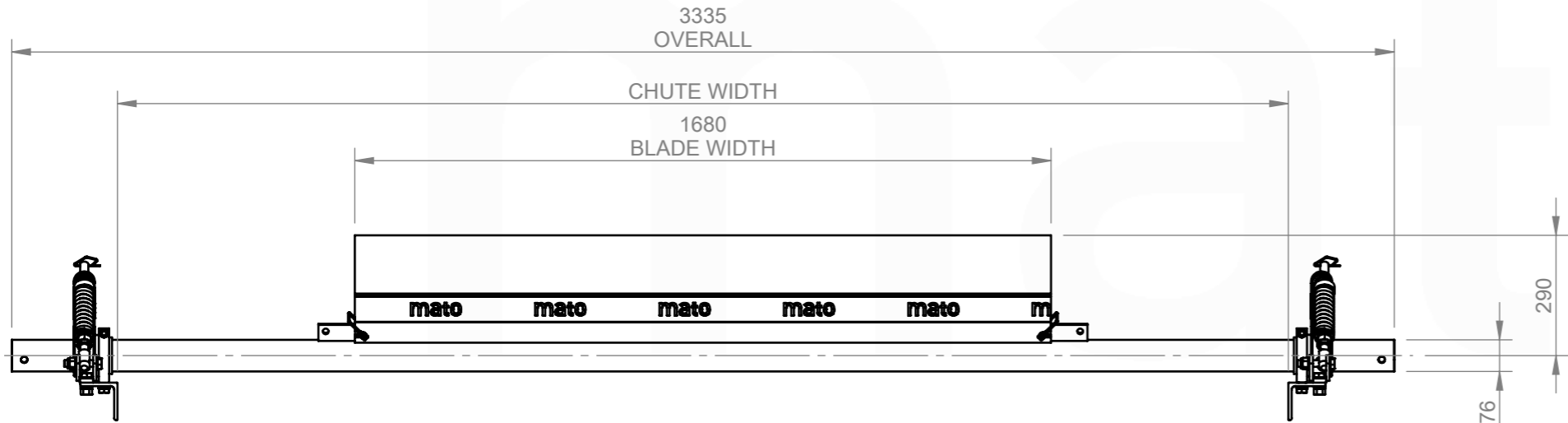

CHUTE CUT OUT DETAIL:  
REFER TO CUT OUT TEMPLATE  
MDP235 CS1 INSTALLATION TEMPLATE

ITEM NO.	DESCRIPTION	QTY.	PART No.	MASS k/g
1	MDP 76.1 CS1 DUAL COMPRESSION SPRING ASSEMBLY (YELLOW SPRING)	1	81 144 00 80	17.93
2	MDP235-P2-1650-1700	1	81 140 32 26	26.92
3	MDP235 BLADE RETAINING PIN	2	81 314 23	0.08
4	MDP235-76-2000	1	81 014 31	42.49

REV.	DESCRIPTION	BY	APR'VD	DATE
A	ISSUED FOR CONSTRUCTION	JS	DG	24/06/25

MATERIAL: N/A	DRAWN BY JS	DESCRIPTION: <b>MDP235-P2-CS1-2000/300</b>	PROFILE CUT ITEMS: TO BE CUT FROM SUPPLIED DXF CAD FILE WHERE APPLICABLE ADDITIONAL DIMENSIONS CAN BE PROVIDED ON REQUEST. DO NOT SCALE IF IN DOUBT  © COPYRIGHT, ALL RIGHTS RESERVED	<b>mato</b>  MATO AUSTRALIA PTY LTD (INCORPORATED IN NSW) ABN 62 050 057 726  39 BONVILLE AVE THORNTON NSW 2322 PH: 1300 850 795 FAX: (02)4936 1388		
FINISH: N/A	CHECKED DG 24/06/25					
COLOUR: N/A	APPROVED DG 24/06/25					
MFG'D: INTERNAL	CREATED 6/06/2025					
SCALE: DO NOT SCALE	MASS: 87.49 KG	PART NO. <b>81 144 32 43</b>	DRAWING NO. <b>7918</b>	PG. SIZE A3	SHEET 1 / 1	REV A

C:\Mato\Auto\Auto\Production\NEW FOLDER STRUCTURE\PRIMARY CLEANERS\MDP - PRIMARY CLEANERS\MDP235\144 32 43\CAD FILES\91 144 32 43