

- ASSEMBLY NOTES:
1. UNLESS DRAWINGS ARE MARKED "FOR CONSTRUCTION", THEY SHALL NOT BE USED FOR CONSTRUCTION PURPOSES
 2. DO NOT OBTAIN DIMENSIONS BY SCALING FROM DRAWING
 3. REMOVE ALL BURRS AND SHARP EDGES
 4. ALL CUTS TO BE A MINIMUM OF CLASS 2 $\sqrt{3.2}$ FINISH UNO

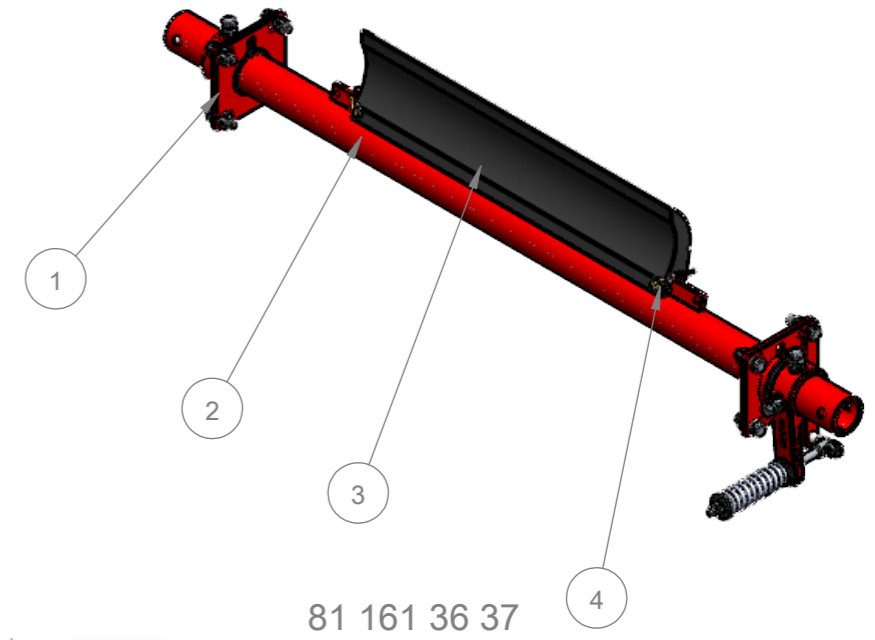

81 161 36 37

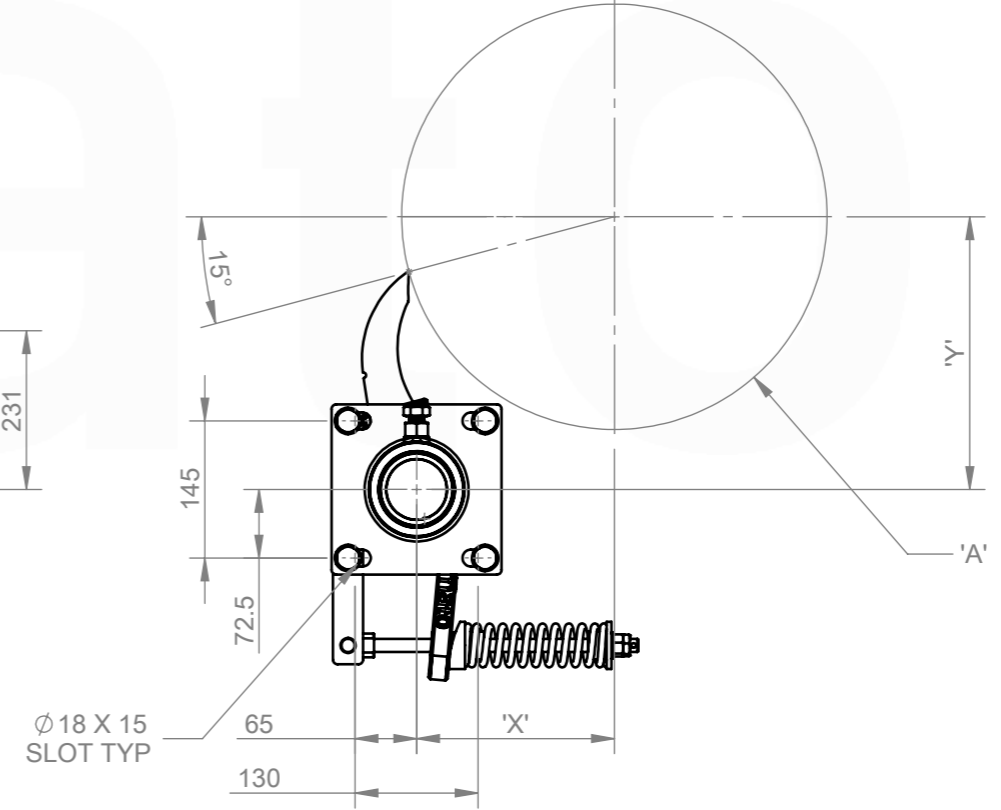
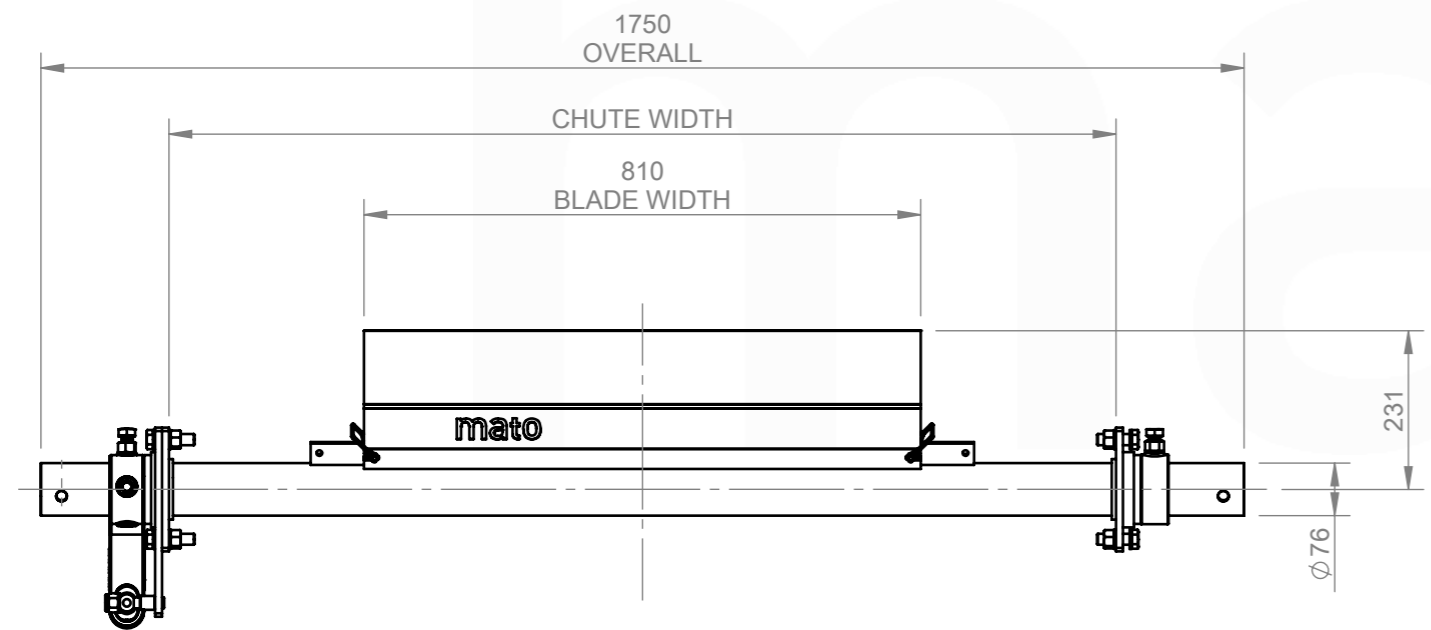

CHUTE CUT OUT DETAIL:
REFER TO CUT OUT TEMPLATE
MDP185HD CS2 INSTALLATION TEMPLATE

ITEM NO.	DESCRIPTION	QTY.	PART NO.	MASS K/G
1	73.0 MD PRIMARY COMPRESSION SPRING CS2 (SILVER) END ASSEMBLY	1	81 161 00 74	11.60
2	MDP185-76-1000	1	81 014 07	21.05
3	MDP185-P2-800	1	81 140 22 30	8.27
4	MDP120/185 BLADE RETAINING PIN	2	81 312 15	0.04

<p>REVISIONS</p> <table border="1"> <thead> <tr> <th>REV.</th> <th>DESCRIPTION</th> <th>BY</th> <th>APR'VD</th> <th>DATE</th> </tr> </thead> <tbody> <tr> <td>A</td> <td>ISSUED FOR CONSTRUCTION</td> <td>JS</td> <td>DG</td> <td>04/06/25</td> </tr> </tbody> </table>					REV.	DESCRIPTION	BY	APR'VD	DATE	A	ISSUED FOR CONSTRUCTION	JS	DG	04/06/25	<p>MACHINING AND FABRICATION TOLERANCES UNO: (ALL DIMENSIONS IN mm)</p> <p>DIMENSIONAL TOLERANCE: PIPE STRAIGHTNESS</p> <p>X.X ±1.0 <1000 ±3.0</p> <p>X.XX ±0.5 <2000 ±6.0</p> <p>X.XXX ±0.1 <3000 ±9.0</p> <p>X.XXXX ±0.01</p> <p>ANGLE: X.X ±1.0° X.XX ±0.5°</p> <p>HOLE CENTERS: ±0.5</p> <p>THERMAL CUTTING: ±1.0</p> <p>WELDMENTS: ±2.0</p> <p>CASTINGS: REFER TO CASTING NOTES</p> <p>MACHINING "ROUGH" TO ISO 2768-vL</p> <p>MACHINING STD: TO ISO 2768-mK</p> <p>POLYURETHANE: ±2.0</p> <p>WELD SYMBOLS: IN ACCORDANCE TO ISO 2553</p> <p>MACHINED SURFACES UNO:</p> <p>TO BE $\sqrt{12.5}$ WHERE INDICATED "ROUGH"</p> <p>TO BE $\sqrt{3.2}$ WHERE NOT INDICATED</p>		<p>MATERIAL: N/A</p> <p>FINISH: N/A</p> <p>COLOUR: N/A</p> <p>MFG'D: INTERNAL</p> <p>SCALE: DO NOT SCALE</p>		<p>DRAWN BY: JS</p> <p>CHECKED: DG 04/06/25</p> <p>APPROVED: DG 04/06/25</p> <p>CREATED: 28/05/2025</p>		<p>DESCRIPTION: MDP185HD-P2-CS2-1000/200</p> <p>PART NO.: 81 161 36 37</p> <p>MASS: 41.00 KG</p>		<p>PROFILE CUT ITEMS: TO BE CUT FROM SUPPLIED DXF CAD FILE WHERE APPLICABLE. ADDITIONAL DIMENSIONS CAN BE PROVIDED ON REQUEST. DO NOT SCALE IF IN DOUBT.</p> <p>© COPYRIGHT, ALL RIGHTS RESERVED</p> <p>THIS DRAWING IS STRICTLY CONFIDENTIAL AND MUST NOT BE COPIED, REPRODUCED OR ADAPTED, NOR MAY ARTICLES BE MANUFACTURED IN ACCORDANCE WITH THE DRAWING WITHOUT PRIOR WRITTEN PERMISSION OF MATO AUSTRALIA PTY LTD.</p>		<p>mato</p> <p>MATO AUSTRALIA PTY LTD (INCORPORATED IN NSW) ABN 82 050 057 728</p> <p>39 BONVILLE AVE THORNTON NSW 2322 PH: 1300 850 795 FAX: (02)4936 1388</p>	
					REV.	DESCRIPTION	BY	APR'VD	DATE																	
A	ISSUED FOR CONSTRUCTION	JS	DG	04/06/25																						
<p>DRAWING NO.: 6939</p> <p>PG. SIZE: A3</p> <p>SHEET: 1 / 1</p> <p>REV: A</p>		<p>3RD ANGLE PROJECTION</p>																								

C:\Matovault\Matovault\Production\NEW FOLDER STRUCTURE\PRIMARY CLEANERS\MDP - PRIMARY CLEANERS\CS2 - END ASSEMBLIES\MDP185HD\811613637\CAD FILES\811613637