

- ASSEMBLY NOTES:
1. UNLESS DRAWINGS ARE MARKED "FOR CONSTRUCTION", THEY SHALL NOT BE USED FOR CONSTRUCTION PURPOSES
 2. DO NOT OBTAIN DIMENSIONS BY SCALING FROM DRAWING
 3. REMOVE ALL BURRS AND SHARP EDGES
 4. ALL CUTS TO BE A MINIMUM OF CLASS 2 $\sqrt{3.2}$ FINISH UNO

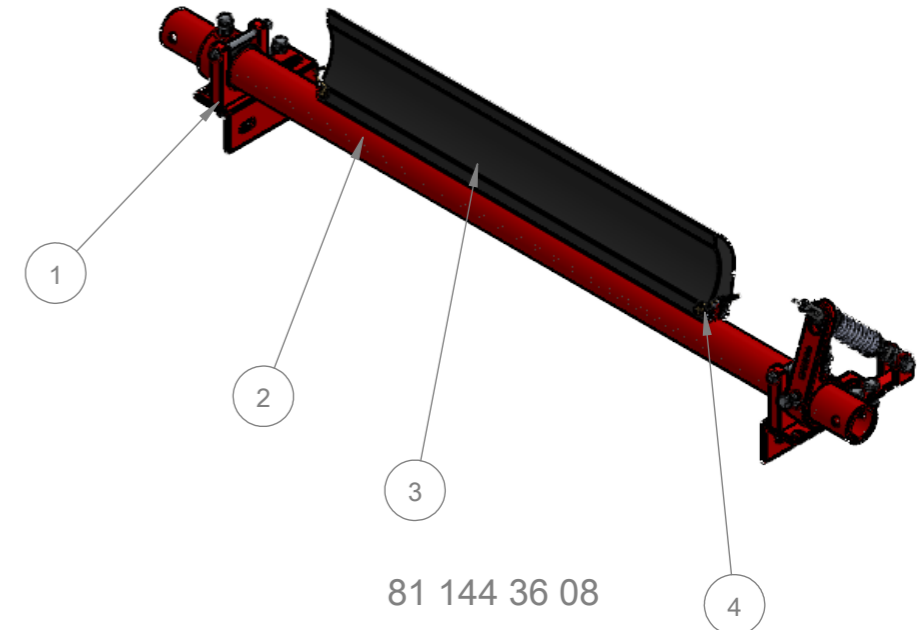

81 144 36 08

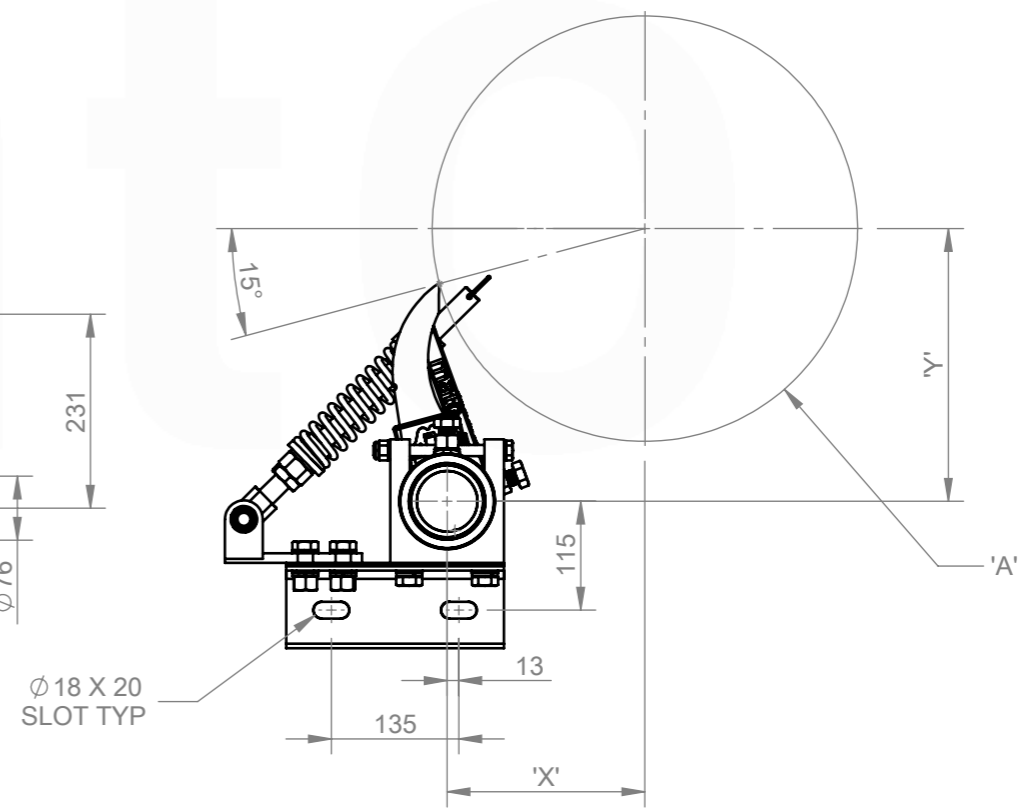
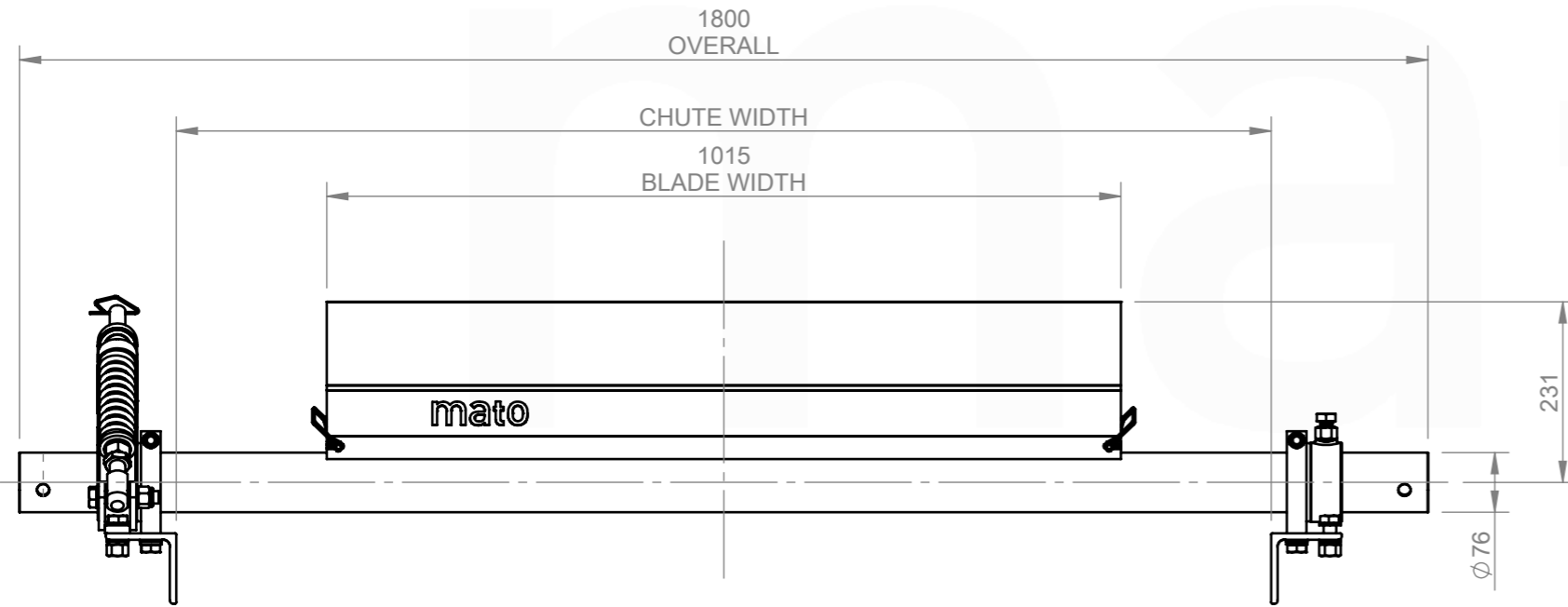

ITEM NO.	DESCRIPTION	QTY.	PART No.	MASS k/g
1	MDP 76.1 CS1 COMPRESSION SPRING END ASSEMBLY COMPLETE (9 SILVER SPRING)	1	81 144 00 74	14.72
2	MDP185-76-1050	1	81 014 08	21.71
3	MDP185-P2-1000	1	81 140 22 18	10.37
4	MDP120/185 BLADE RETAINING PIN	2	81 312 15	0.04

CHUTE CUT OUT DETAIL:
REFER TO CUT OUT TEMPLATE
MDP185HD CS1 INSTALLATION TEMPLATE

REV.	DESCRIPTION	BY	APRVD	DATE
A	ISSUED FOR CONSTRUCTION	JS	DG	03/06/25

<p>MACHINING AND FABRICATION TOLERANCES UNO: (ALL DIMENSIONS IN mm)</p> <p>DIMENSIONAL TOLERANCE: PIPE STRAIGHTNESS</p> <p>X.X ±1.0 <1000 ±3.0</p> <p>X.XX ±0.5 <2000 ±6.0</p> <p>X.XXX ±0.1 <3000 ±9.0</p> <p>X.XXXX ±0.01</p> <p>ANGLE: X.X ±1.0° X.XX ±0.5°</p> <p>THERMAL CUTTING: ±1.0</p> <p>WELDMENTS: ±2.0</p> <p>CASTINGS: REFER TO CASTING NOTES</p> <p>MACHINING "ROUGH" TO ISO 2768-VL</p> <p>MACHINING STD: TO ISO 2768-mK</p> <p>POLYURETHANE: ±2.0</p> <p>WELD SYMBOLS: IN ACCORDANCE TO ISO 2553</p> <p>MACHINED SURFACES UNO:</p> <p>TO BE $\sqrt{12.5}$ WHERE INDICATED "ROUGH"</p> <p>TO BE $\sqrt{3.2}$ WHERE NOT INDICATED</p>	<p>MATERIAL: N/A</p> <p>FINISH: N/A</p> <p>COLOUR: N/A</p> <p>MFG'D: INTERNAL</p> <p>SCALE: DO NOT SCALE</p>	<p>DRAWN BY: JS</p> <p>CHECKED: DG 03/06/25</p> <p>APPROVED: DG 03/06/25</p> <p>CREATED: 28/05/2025</p>	<p>DESCRIPTION: MDP185HD-P2-CS1-1050/50</p> <p>PART NO.: 81 144 36 08</p> <p>MASS: 46.88 KG</p>	<p>PROFILE CUT ITEMS: TO BE CUT FROM SUPPLIED DXF CAD FILE WHERE APPLICABLE. ADDITIONAL DIMENSIONS CAN BE PROVIDED ON REQUEST. DO NOT SCALE IF IN DOUBT.</p> <p>© COPYRIGHT, ALL RIGHTS RESERVED</p> <p>THIS DRAWING IS STRICTLY CONFIDENTIAL AND MUST NOT BE COPIED, REPRODUCED OR ADAPTED, NOR MAY ARTICLES BE MANUFACTURED IN ACCORDANCE WITH THE DRAWING WITHOUT PRIOR WRITTEN PERMISSION OF MATO AUSTRALIA PTY LTD.</p>	<p>mato</p> <p>MATO AUSTRALIA PTY LTD (INCORPORATED IN NSW) ABN 62 050 057 726</p> <p>39 BONVILLE AVE THORNTON NSW 2322 PH: 1300 850 795 FAX: (02)4936 1388</p>
	<p>DRAWING NO. 6897</p>		<p>PG. SIZE: A3</p> <p>SHEET: 1 / 1</p> <p>REV: A</p>		

C:\Matovault\Matovault\Production\NEW FOLDER STRUCTURE\PRIMARY CLEANERS\MDP - PRIMARY CLEANERS\CS1 - END ASSEMBLIES\MDP185HD\81 144 36 08\CAD FILES\81 144 36 08