

ASSEMBLY NOTES:

1. UNLESS DRAWINGS ARE MARKED "FOR CONSTRUCTION", THEY SHALL NOT BE USED FOR CONSTRUCTION PURPOSES
2. DO NOT OBTAIN DIMENSIONS BY SCALING FROM DRAWING
3. REMOVE ALL BURRS AND SHARP EDGES
4. ALL CUTS TO BE A MINIMUM OF CLASS 2 $\sqrt{3.2}$ FINISH UNO

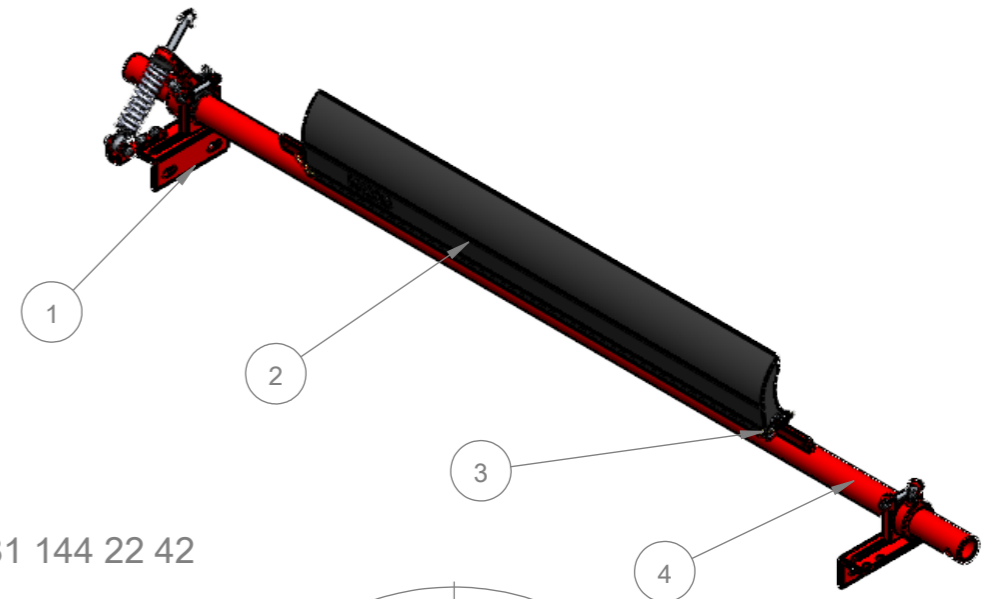

81 144 22 42

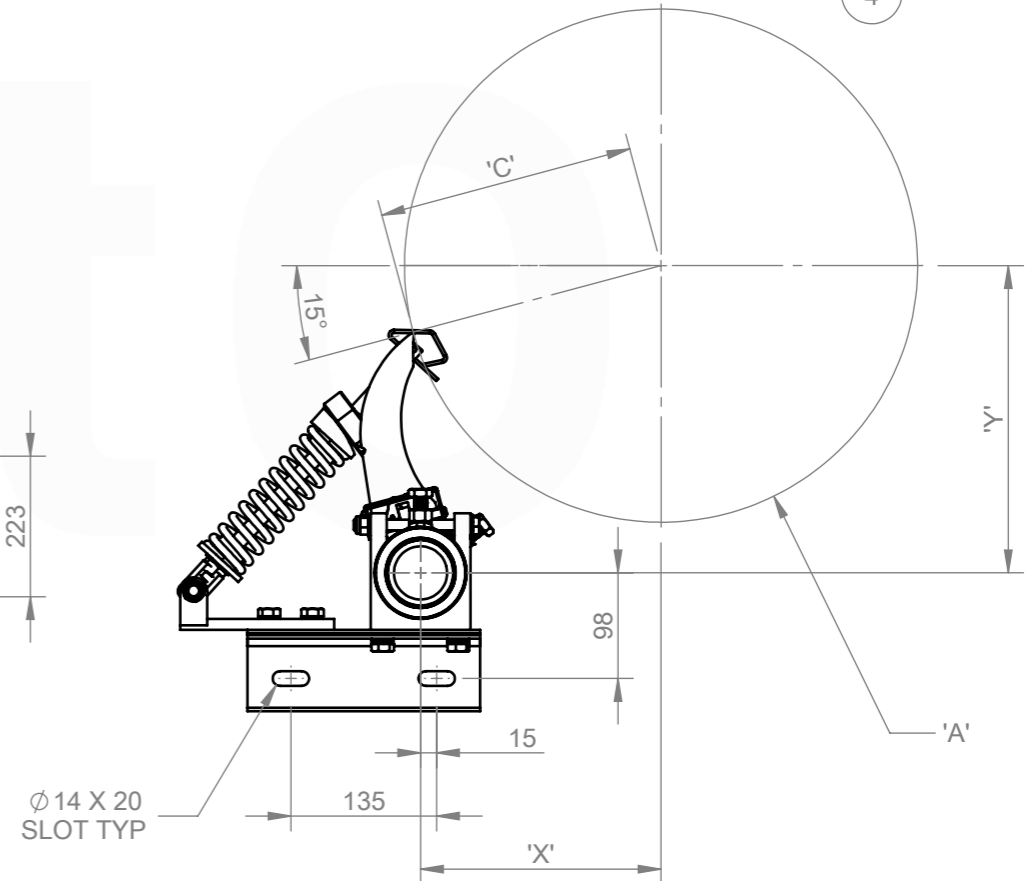
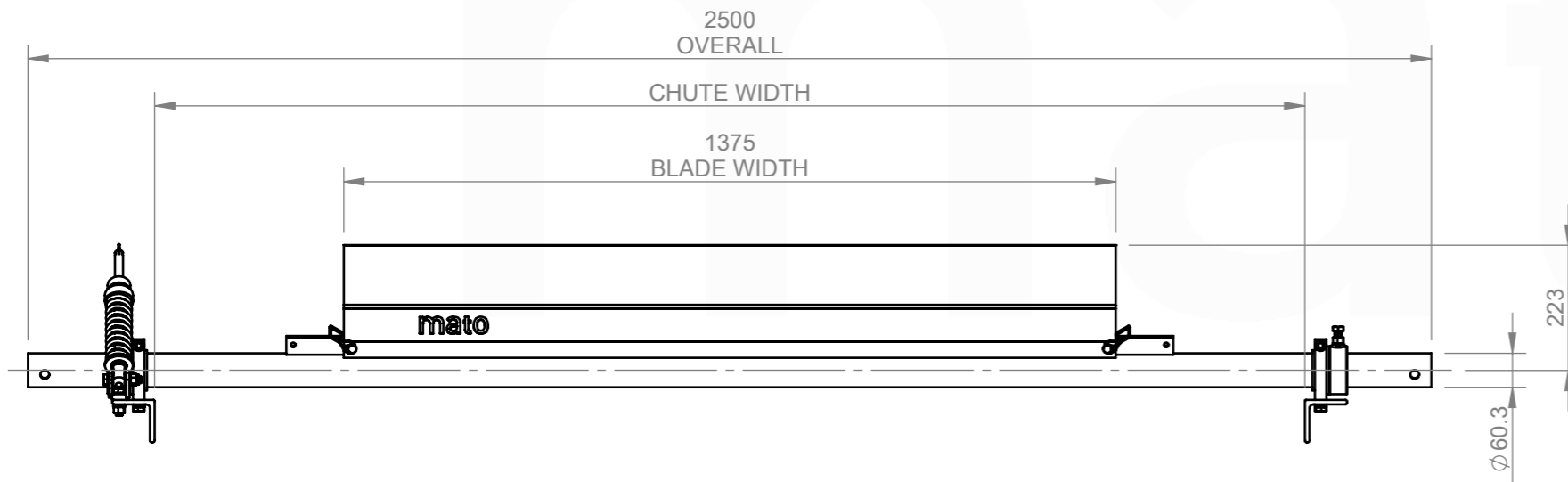

CHUTE CUT OUT DETAIL:
REFER TO CUT OUT TEMPLATE
MDP185 CS1 INSTALLATION TEMPLATE

ITEM NO.	DESCRIPTION	QTY.	PART No.	MASS k/g
1	MDP 60.3 CS1 COMPRESSION SPRING END ASSEMBLY COMPLETE (SILVER SPRING)	1	81 144 00 62	9.33
2	MDP185-P2-1400	1	81 140 22 23	14.05
3	MDP120/185 BLADE RETAINING PIN	2	81 312 15	0.04
4	MDP185-60-1600 SHAFT	1	81 012 12	22.48

REVISIONS REV. DESCRIPTION BY APRVD DATE A ISSUED FOR CONSTRUCTION JS DG 22/05/25					MACHINING AND FABRICATION TOLERANCES UNO: (ALL DIMENSIONS IN mm) DIMENSIONAL TOLERANCE: PIPE STRAIGHTNESS X.X ±1.0 <1000 ±3.0 X.XX ±0.5 <2000 ±6.0 X.XXX ±0.1 <3000 ±9.0 X.XXXX ±0.01 ANGLE: X.X ±1.0° X.XX ±0.5° THERMAL CUTTING: ±1.0 WELDMENTS: ±2.0 CASTINGS: REFER TO CASTING NOTES MACHINING "ROUGH" TO ISO 2768-vL MACHINING STD: TO ISO 2768-mK POLYURETHANE: ±2.0 WELD SYMBOLS: IN ACCORDANCE TO ISO 2553 MACHINED SURFACES UNO: TO BE $\sqrt{12.5}$ WHERE INDICATED "ROUGH" TO BE $\sqrt{3.2}$ WHERE NOT INDICATED		MATERIAL: N/A FINISH: N/A COLOUR: N/A MFG'D: INTERNAL SCALE: DO NOT SCALE		DRAWN BY JS CHECKED DG 22/05/25 APPROVED DG 22/05/25 CREATED 13/05/2025		DESCRIPTION: MDP185-P2-CS1-1600/200 PART NO. 81 144 22 42 MASS: 45.94 KG		PROFILE CUT ITEMS: TO BE CUT FROM SUPPLIED DXF CAD FILE WHERE APPLICABLE ADDITIONAL DIMENSIONS CAN BE PROVIDED ON REQUEST. DO NOT SCALE IF IN DOUBT © COPYRIGHT, ALL RIGHTS RESERVED THIS DRAWING IS STRICTLY CONFIDENTIAL AND MUST NOT BE COPIED, REPRODUCED OR ADAPTED, NOR MAY ARTICLES BE MANUFACTURED IN ACCORDANCE WITH THE DRAWING WITHOUT PRIOR WRITTEN PERMISSION OF MATO AUSTRALIA PTY LTD.		MATO AUSTRALIA PTY LTD (INCORPORATED IN NSW) ABN 62 050 057 726 39 BONVILLE AVE THORNTON NSW 2322 PH: 1300 850 795 FAX: (02)4936 1388	
					DRAWING NO. 7846 PG. SIZE A3 SHEET 1 / 1 REV A		3RD ANGLE PROJECTION									

C:\InfoVault\InfoVault\01-Production\NEW FOLDER STRUCTURE\PRIMARY CLEANERS\MDP - PRIMARY CLEANERS\CS1 - END ASSEMBLIES\MDP185\144 22 42\CAD FILES\81 144 22 42