

- ASSEMBLY NOTES:
1. UNLESS DRAWINGS ARE MARKED "FOR CONSTRUCTION", THEY SHALL NOT BE USED FOR CONSTRUCTION PURPOSES
 2. DO NOT OBTAIN DIMENSIONS BY SCALING FROM DRAWING
 3. REMOVE ALL BURRS AND SHARP EDGES
 4. ALL CUTS TO BE A MINIMUM OF CLASS 2 $\sqrt{3.2}$ FINISH UNO

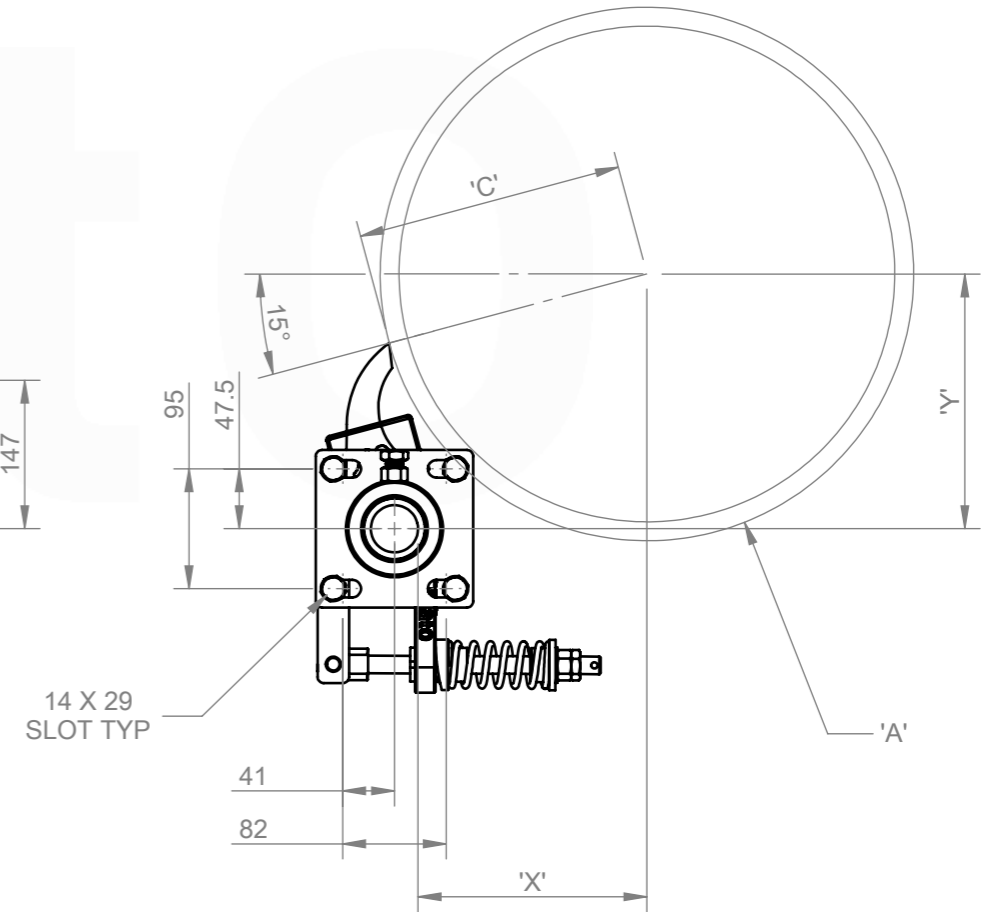
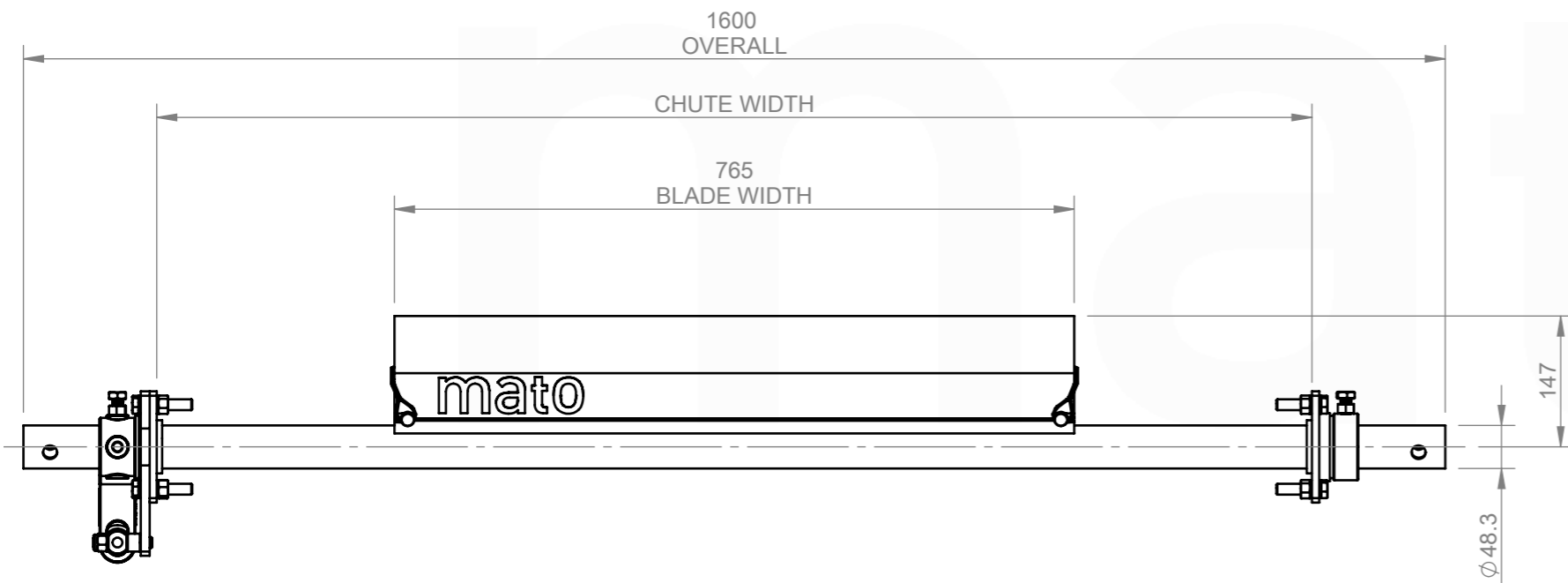
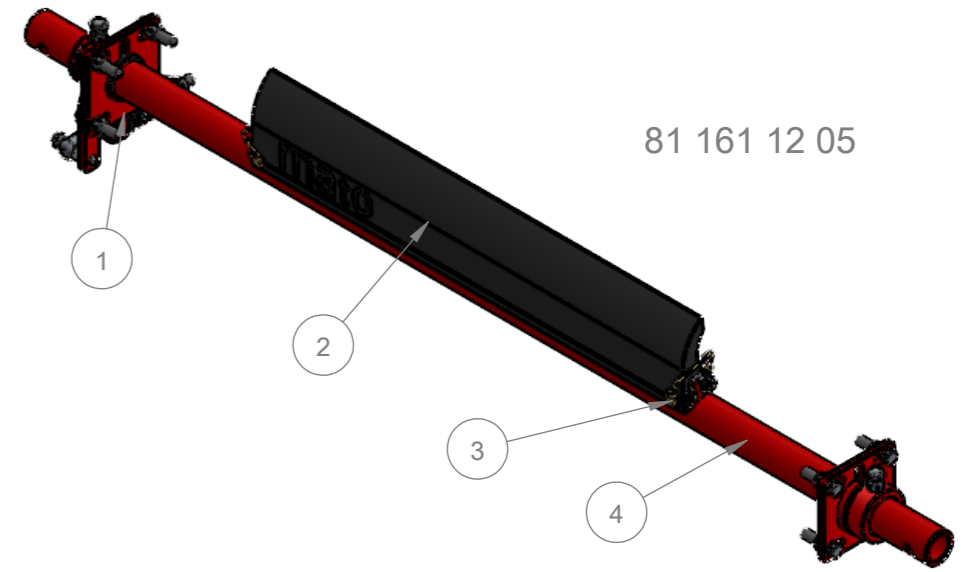

ITEM NO.	DESCRIPTION	QTY.	PART No.	MASS k/g
1	48.3 LD Primary Compression Spring CS2 (Black) End Assembly	1	81 161 00 48	4.86
2	MDP120-P2-750	1	81 140 12 15	4.30
3	MDP120/185 BLADE RETAINING PIN	2	81 312 15	0.04
4	MDP120-48-800 SHAFT	1	81 011 05	10.93

CHUTE CUT OUT DETAIL:
REFER TO CUT OUT TEMPLATE
MDP120 CS2 INSTALLATION TEMPLATE

<p>REVISIONS</p> <table border="1"> <thead> <tr> <th>REV.</th> <th>DESCRIPTION</th> <th>BY</th> <th>APRVD</th> <th>DATE</th> </tr> </thead> <tbody> <tr> <td>A</td> <td>ISSUED FOR CONSTRUCTION</td> <td>JS</td> <td>DG</td> <td>16/04/25</td> </tr> </tbody> </table>					REV.	DESCRIPTION	BY	APRVD	DATE	A	ISSUED FOR CONSTRUCTION	JS	DG	16/04/25	<p>MACHINING AND FABRICATION TOLERANCES UNO: (ALL DIMENSIONS IN mm)</p> <p>DIMENSIONAL TOLERANCE: PIPE STRAIGHTNESS</p> <p>X.X ±1.0 <1000 ±3.0</p> <p>X.XX ±0.5 <2000 ±6.0</p> <p>X.XXX ±0.1 <3000 ±9.0</p> <p>X.XXXX ±0.01</p> <p>ANGLE: X.X ±1.0° X.XX ±0.5°</p> <p>THERMAL CUTTING: ±1.0</p> <p>WELDMENTS: ±2.0</p> <p>CASTINGS: REFER TO CASTING NOTES</p> <p>MACHINING "ROUGH" TO ISO 2768-vL</p> <p>MACHINING STD: TO ISO 2768-mK</p> <p>POLYURETHANE: ±2.0</p> <p>WELD SYMBOLS: IN ACCORDANCE TO ISO 2553</p> <p>MACHINED SURFACES UNO: $\sqrt{3.2}$</p> <p>TO BE $\sqrt{3.2}$ WHERE INDICATED "ROUGH"</p> <p>TO BE $\sqrt{3.2}$ WHERE NOT INDICATED</p>		<p>MATERIAL: N/A</p> <p>FINISH: N/A</p> <p>COLOUR: N/A</p> <p>MFG'D: INTERNAL</p> <p>SCALE: DO NOT SCALE</p>		<p>DRAWN BY: JS</p> <p>CHECKED: DG 16/04/25</p> <p>APPROVED: DG 16/04/25</p> <p>CREATED: 6/02/2025</p>		<p>DESCRIPTION: MDP120-P2-CS2-800-50</p> <p>PART NO.: 81 161 12 05</p> <p>MASS: 20.17 KG</p>		<p>PROFILE CUT ITEMS: TO BE CUT FROM SUPPLIED DXF CAD FILE WHERE APPLICABLE. ADDITIONAL DIMENSIONS CAN BE PROVIDED ON REQUEST. DO NOT SCALE IF IN DOUBT.</p> <p>© COPYRIGHT, ALL RIGHTS RESERVED</p> <p>THIS DRAWING IS STRICTLY CONFIDENTIAL AND MUST NOT BE COPIED, REPRODUCED OR ADAPTED, NOR MAY ARTICLES BE MANUFACTURED IN ACCORDANCE WITH THE DRAWING WITHOUT PRIOR WRITTEN PERMISSION OF MATO AUSTRALIA PTY LTD.</p>		<p>mato</p> <p>MATO AUSTRALIA PTY LTD (INCORPORATED IN NSW) ABN 82 050 057 726</p> <p>39 BONVILLE AVE THORNTON NSW 2322 PH: 1300 850 795 FAX: (02)4936 1388</p>	
					REV.	DESCRIPTION	BY	APRVD	DATE																	
A	ISSUED FOR CONSTRUCTION	JS	DG	16/04/25																						
<p>DRAWING NO. 7743</p> <p>PG. SIZE A3</p> <p>SHEET 1 / 1</p> <p>REV A</p>		<p>3RD ANGLE PROJECTION</p>																								

C:\Matovault\Matovault\Production\NEW FOLDER STRUCTURE\PRIMARY CLEANERS\MDP - PRIMARY CLEANERS\CS2 - END ASSEMBLIES\MDP120P1 161 12 05\CAD FILES\81 161 12 05