

ASSEMBLY NOTES:

- UNLESS DRAWINGS ARE MARKED "FOR CONSTRUCTION", THEY SHALL NOT BE USED FOR CONSTRUCTION PURPOSES
- DO NOT OBTAIN DIMENSIONS BY SCALING FROM DRAWING
- REMOVE ALL BURRS AND SHARP EDGES
- ALL CUTS TO BE A MINIMUM OF CLASS 2 $\sqrt{3.2}$ FINISH UNO

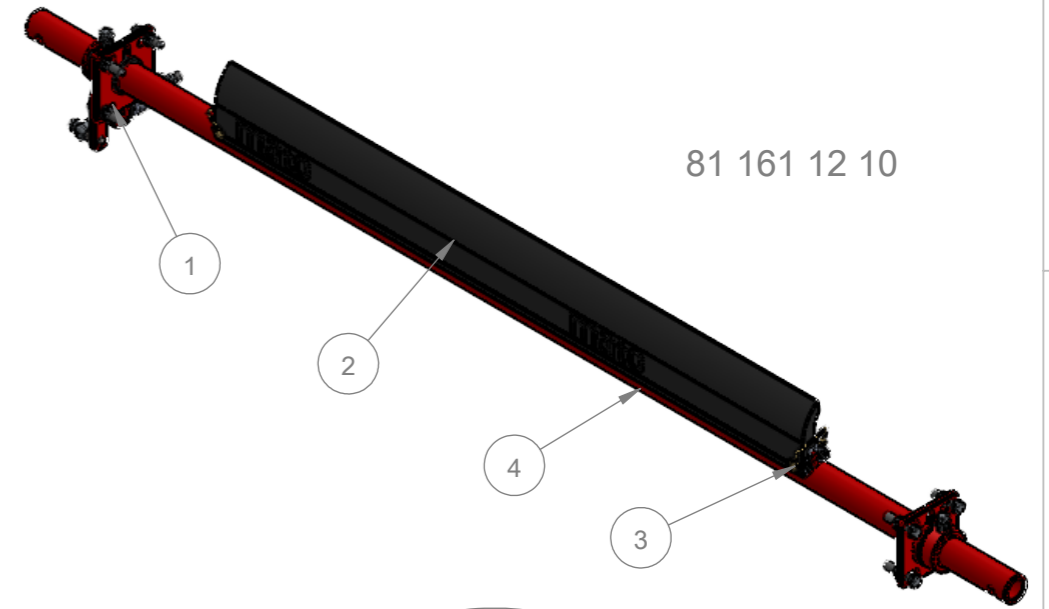

81 161 12 10

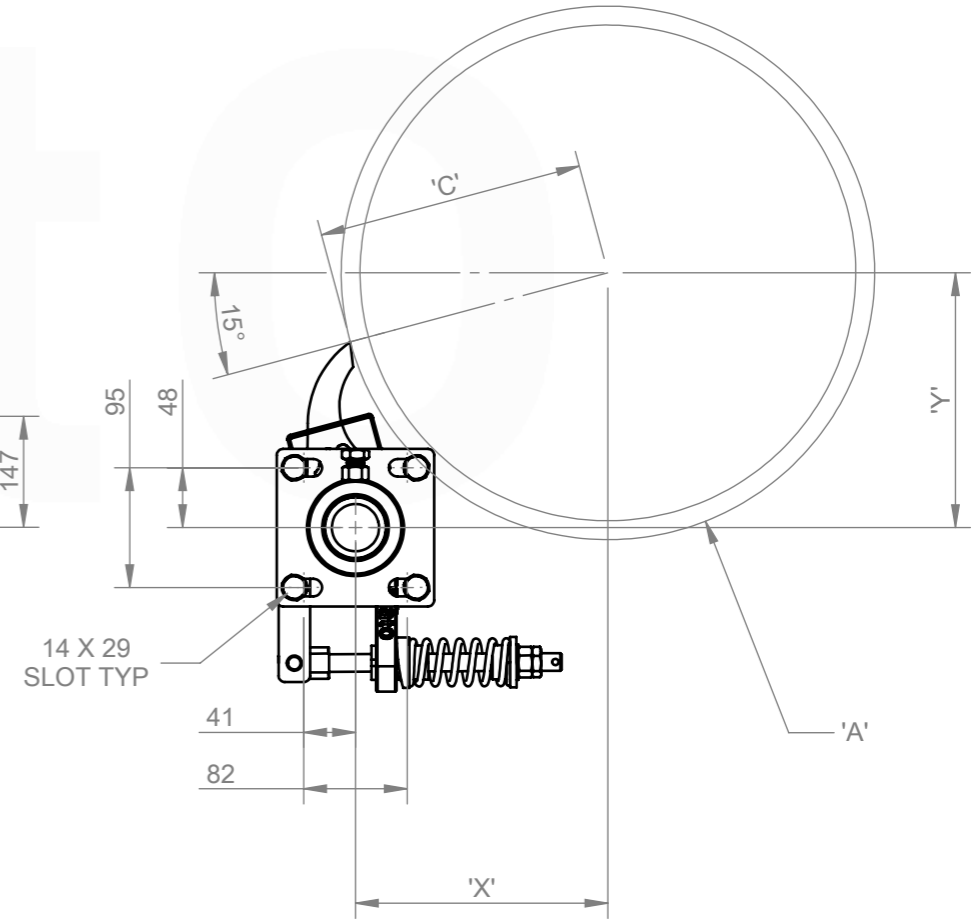
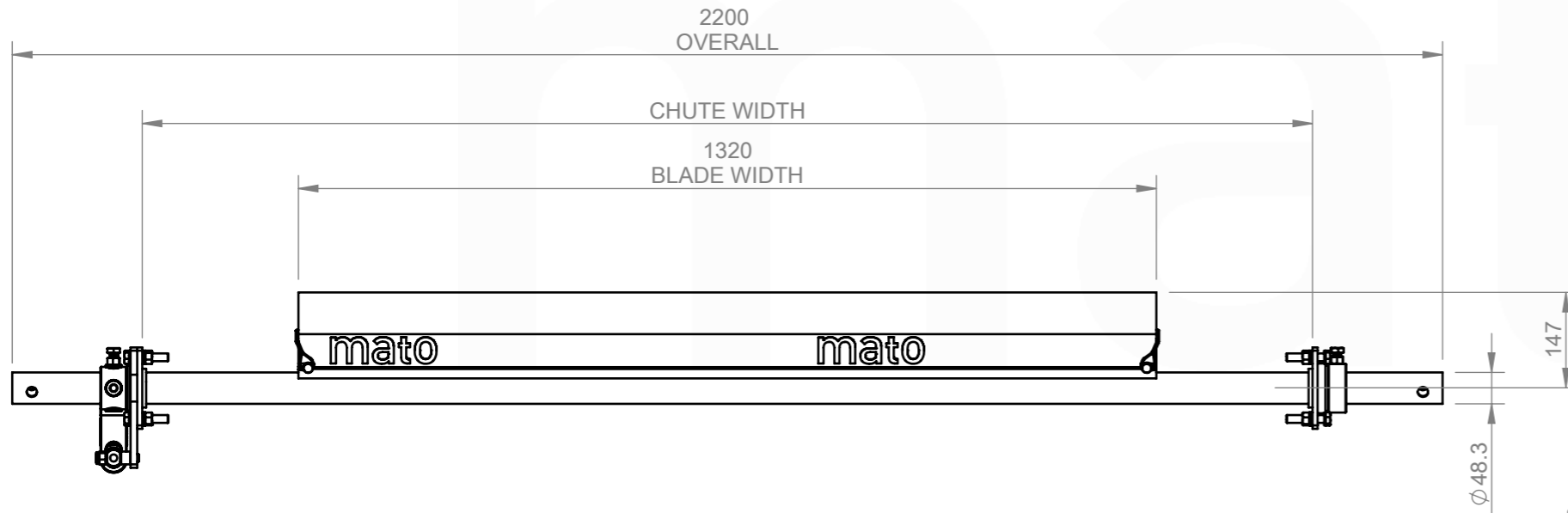

ITEM NO.	DESCRIPTION	QTY.	PART No.	MASS k/g
1	48.3 LD PRIMARY COMPRESSION SPRING CS2 (WHITE) END ASSEMBLY	1	81 161 00 50	5.00
2	MDP120-P2-1350	1	81 140 12 23	7.44
3	MDP120/185 BLADE RETAINING PIN	2	81 312 15	0.04
4	MDP120-48-1400 SHAFT	1	81 011 10	15.72

CHUTE CUT OUT DETAIL:
REFER TO CUT OUT TEMPLATE
MDP120 CS2 INSTALLATION TEMPLATE

REV.	DESCRIPTION	BY	APRVD	DATE
A	ISSUED FOR CONSTRUCTION	JS	DG	16/04/25

MATERIAL: N/A	DRAWN BY JS	DESCRIPTION: MDP120-P2-CS2-1400-50	PROFILE CUT ITEMS: TO BE CUT FROM SUPPLIED DXF CAD FILE WHERE APPLICABLE ADDITIONAL DIMENSIONS CAN BE PROVIDED ON REQUEST. DO NOT SCALE IF IN DOUBT © COPYRIGHT, ALL RIGHTS RESERVED	mato MATO AUSTRALIA PTY LTD (INCORPORATED IN NSW) ABN 82 050 057 728 38 BONVILLE AVE THORNTON NSW 2322 PH: 1300 850 795 FAX: (02)4936 1388
FINISH: N/A	CHECKED DG 16/04/25			
COLOUR: N/A	APPROVED DG 16/04/25	PART NO. 81 161 12 10	THIS DRAWING IS STRICTLY CONFIDENTIAL AND MUST NOT BE COPIED, REPRODUCED OR ADAPTED, NOR MAY ARTICLES BE MANUFACTURED IN ACCORDANCE WITH THE DRAWING WITHOUT PRIOR WRITTEN PERMISSION OF MATO AUSTRALIA PTY LTD.	PG. SIZE A3
MFG'D: INTERNAL	CREATED 6/02/2025	MASS: 28.25 KG		
SCALE DO NOT SCALE		3RD ANGLE PROJECTION	DRAWING NO. 7748	

C:\Mato\Auto\Auto\Production\NEW FOLDER STRUCTURE\PRIMARY CLEANERS\MDP - PRIMARY CLEANERS\CS2 - END ASSEMBLIES\MDP120P1 161 12 10\CAD FILES\91 161 12 10