

- ASSEMBLY NOTES:
- UNLESS DRAWINGS ARE MARKED "FOR CONSTRUCTION", THEY SHALL NOT BE USED FOR CONSTRUCTION PURPOSES
 - DO NOT OBTAIN DIMENSIONS BY SCALING FROM DRAWING
 - REMOVE ALL BURRS AND SHARP EDGES
 - ALL CUTS TO BE A MINIMUM OF CLASS 2 $\sqrt{3.2}$ FINISH UNO

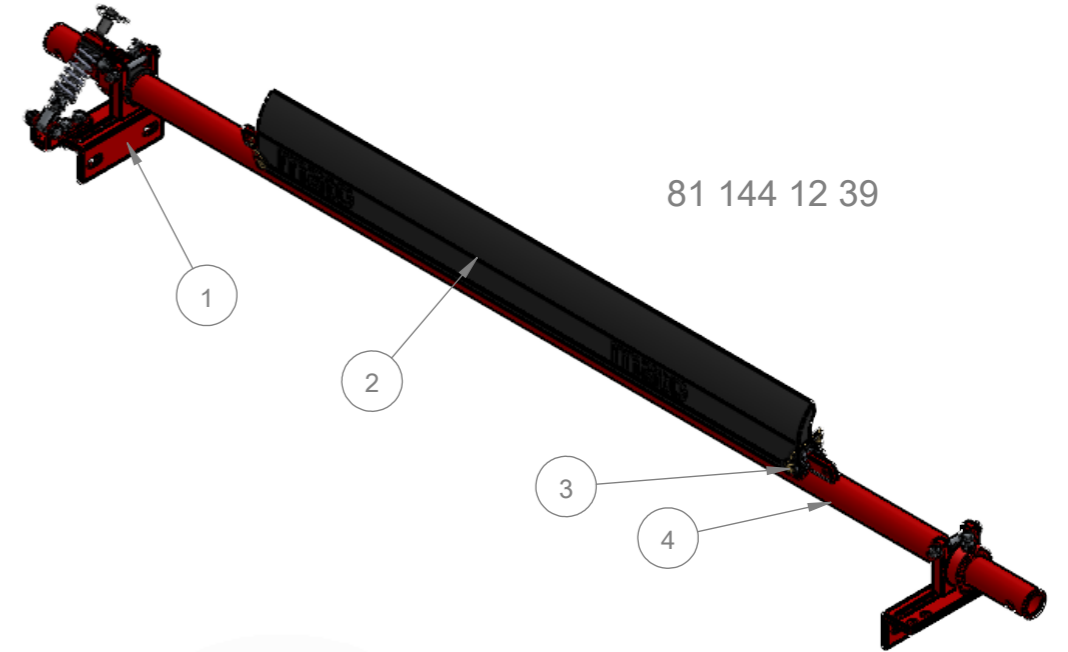

81 144 12 39

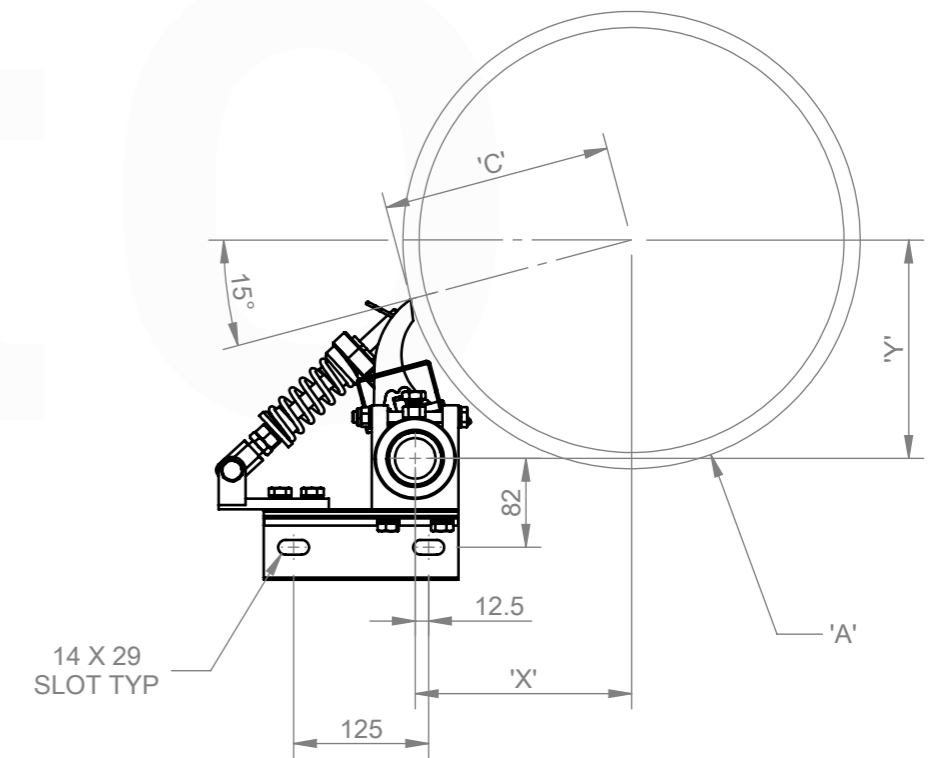
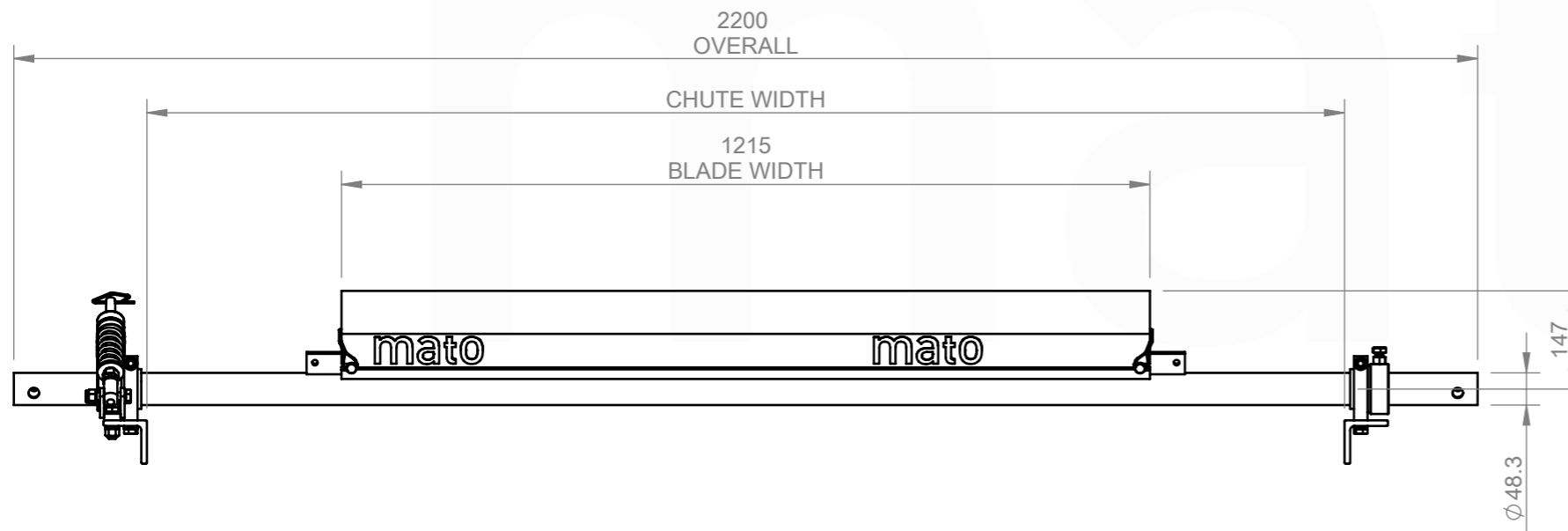

14 X 29
SLOT TYP

| ITEM NO. | DESCRIPTION | QTY. | PART No. | MASS k/g |
|----------|---|------|--------------|----------|
| 1 | MDP 48.3 LD CS1 WHITE SPRING END ASSEMBLY | 1 | 81 144 00 50 | 6.58 |
| 2 | MDP120-P2-1200 | 1 | 81 140 12 21 | 6.85 |
| 3 | MDP120/185 BLADE RETAINING PIN | 2 | 81 312 15 | 0.04 |
| 4 | MDP120-48-1400 SHAFT | 1 | 81 011 10 | 15.72 |

CHUTE CUT OUT DETAIL:
REFER TO CUT OUT TEMPLATE
MDP120 CS1 INSTALLATION TEMPLATE

| <p>REVISIONS</p> <table border="1"> <thead> <tr> <th>REV.</th> <th>DESCRIPTION</th> <th>BY</th> <th>APRVD</th> <th>DATE</th> </tr> </thead> <tbody> <tr> <td>A</td> <td>ISSUED FOR CONSTRUCTION</td> <td>JS</td> <td>DG</td> <td>16/04/25</td> </tr> </tbody> </table> | | | | | REV. | DESCRIPTION | BY | APRVD | DATE | A | ISSUED FOR CONSTRUCTION | JS | DG | 16/04/25 | <p>MACHINING AND FABRICATION TOLERANCES UNO: (ALL DIMENSIONS IN mm)</p> <p>DIMENSIONAL TOLERANCE: PIPE STRAIGHTNESS</p> <p>X.X ±1.0 <1000 ±3.0</p> <p>X.XX ±0.5 <2000 ±6.0</p> <p>X.XXX ±0.1 <3000 ±9.0</p> <p>X.XXXX ±0.01</p> <p>ANGLE: X.X ±1.0° X.XX ±0.5°</p> <p>THERMAL CUTTING: ±1.0</p> <p>WELDMENTS: ±2.0</p> <p>CASTINGS: REFER TO CASTING NOTES</p> <p>MACHINING "ROUGH" TO ISO 2768-vL</p> <p>MACHINING STD: TO ISO 2768-mK</p> <p>POLYURETHANE: ±2.0</p> <p>WELD SYMBOLS: IN ACCORDANCE TO ISO 2553</p> <p>MACHINED SURFACES UNO: $\sqrt{3.2}$ TO BE $\sqrt{3.2}$ WHERE INDICATED "ROUGH" TO BE $\sqrt{3.2}$ WHERE NOT INDICATED</p> | | <p>MATERIAL: N/A</p> <p>FINISH: N/A</p> <p>COLOUR: N/A</p> <p>MFG'D: INTERNAL</p> <p>SCALE: DO NOT SCALE</p> | | <p>DRAWN BY: JS</p> <p>CHECKED: DG 16/04/25</p> <p>APPROVED: DG 16/04/25</p> <p>CREATED: 6/02/2025</p> | | <p>DESCRIPTION: MDP120-P2-CS1-1400-200</p> <p>PART NO.: 81 144 12 39</p> <p>MASS: 29.24 KG</p> | | <p>PROFILE CUT ITEMS: TO BE CUT FROM SUPPLIED DXF CAD FILE WHERE APPLICABLE. ADDITIONAL DIMENSIONS CAN BE PROVIDED ON REQUEST. DO NOT SCALE IF IN DOUBT.</p> <p>© COPYRIGHT, ALL RIGHTS RESERVED</p> <p>THIS DRAWING IS STRICTLY CONFIDENTIAL AND MUST NOT BE COPIED, REPRODUCED OR ADAPTED, NOR MAY ARTICLES BE MANUFACTURED IN ACCORDANCE WITH THE DRAWING WITHOUT PRIOR WRITTEN PERMISSION OF MATO AUSTRALIA PTY LTD.</p> | | <p>mato</p> <p>MATO AUSTRALIA PTY LTD (INCORPORATED IN NSW) ABN 82 050 057 726</p> <p>39 BONVILLE AVE THORNTON NSW 2322 PH 1300 850 795 FAX (02)4936 1388</p> | |
|--|-------------------------|--------------------|----|--------------------|------|--------------|----|-------|------|---|-------------------------|----|----|----------|---|--|--|--|--|--|--|--|--|--|--|--|
| | | | | | REV. | DESCRIPTION | BY | APRVD | DATE | | | | | | | | | | | | | | | | | |
| A | ISSUED FOR CONSTRUCTION | JS | DG | 16/04/25 | | | | | | | | | | | | | | | | | | | | | | |
| <p>DRAWING NO. 7736</p> | | <p>PG. SIZE A3</p> | | <p>SHEET 1 / 1</p> | | <p>REV A</p> | | | | | | | | | | | | | | | | | | | | |

C:\Mato\Auto\Auto\Production\NEW FOLDER STRUCTURE\PRIMARY CLEANERS\MDP - PRIMARY CLEANERS\MDP120\144 12 39\CAD FILES\81 144 12 39